

KOOLAIR

series

DFRE-GR-TR

Thermo-adjustable
blade swirl diffusers

ISO 9001

BUREAU VERITAS
Certification

Sistema de Gestión



www.koolair.com

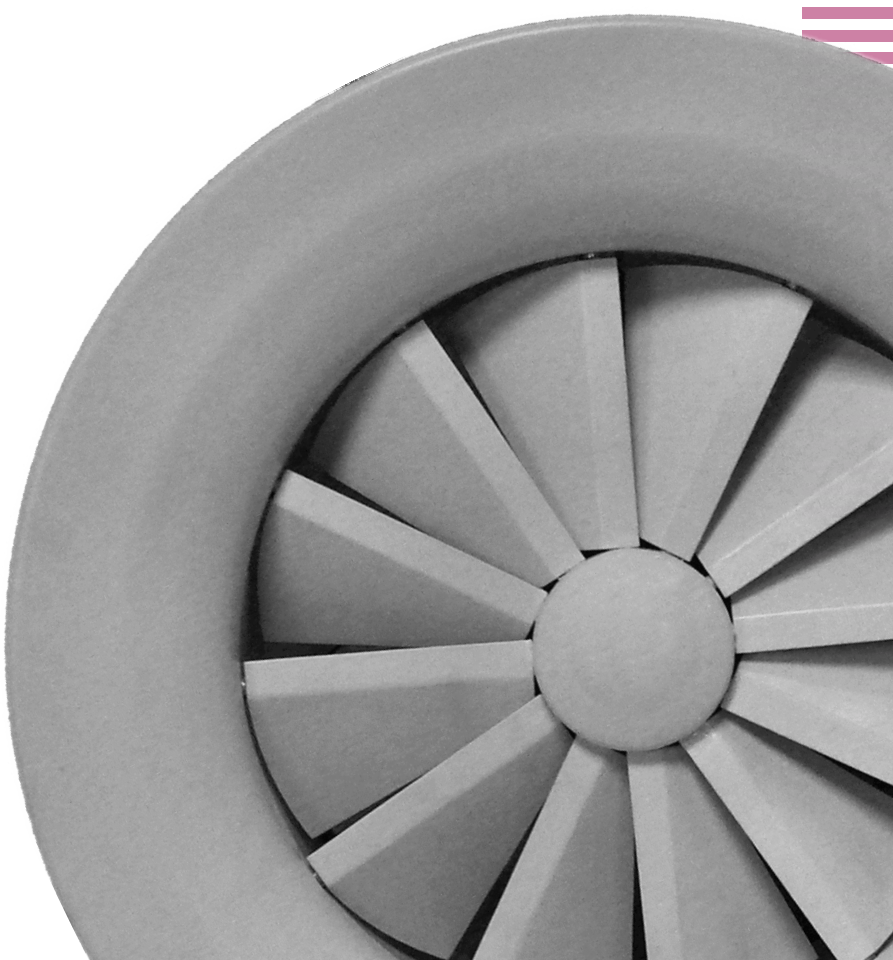

CONTENTS

Description	2
Models and dimensions	3
Technical data	5
Product codes	10

Thermo-adjustable blade swirl diffuser

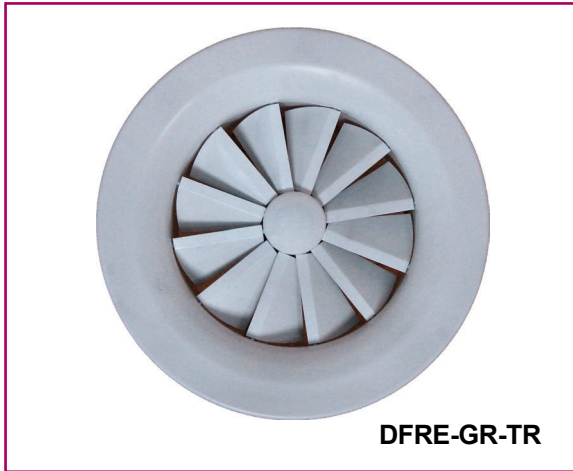

DFRE-GR-TR

Thermo-adjustable swirl diffuser, model DFRE-GR-TR, provides an optimum discharge in cooling (horizontal discharge) and heating (vertical discharge) enabling the diffuser to meet the required comfort criteria by movement of its blades.

The diffuser is available in 6 sizes ranging from Ø200 mm to Ø 500 mm in manually or thermo-adjustable versions. Increasingly stringent design requirements including higher supply flow rates, lower velocities, thermal gradients in the occupied zone and also the aesthetics have made swirl diffusers a better choice for air diffusion.

This is due to its high induction rate which can reduce velocities, airflow and obtain better thermal gradient conditions in the occupied zone.

Operation:

The adjustable blade swirl diffuser allows the air discharge pattern to alter between horizontal and vertical by moving its blades. This movement can be carried out manually or by a thermal element which positions the blades depending on the supply air temperature.

The DFRE-GR-TR diffusers should ideally be mounted at heights in excess of 3.5 m for supplying cooled, isothermal and heated air. This diffuser is an ideal choice for high ceilings applications in areas such as airports, factories and public buildings due to its high aesthetic appeal, ease of installation, regulation, and high air volume capacity.

These diffusers can be incorporated in square panels for adaption into "lay in" tile replacement ceilings.

Made of steel sheet, coated in white RAL 9010. Special finishes available upon request.

The plenum box includes within the spigot a volume control damper, accessible from the side of the plenum, made of perforated sheet. If required plenum boxes can be provided with interior insulation.

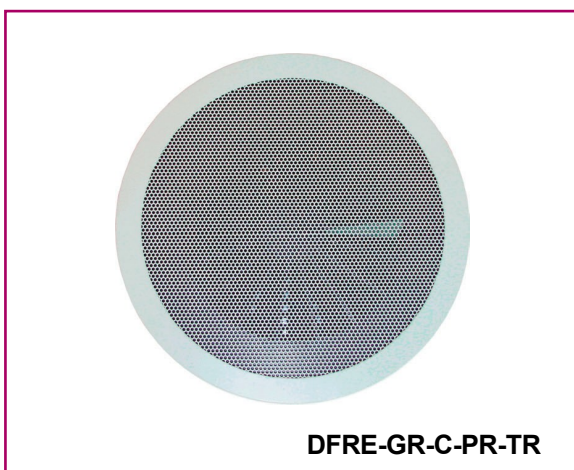
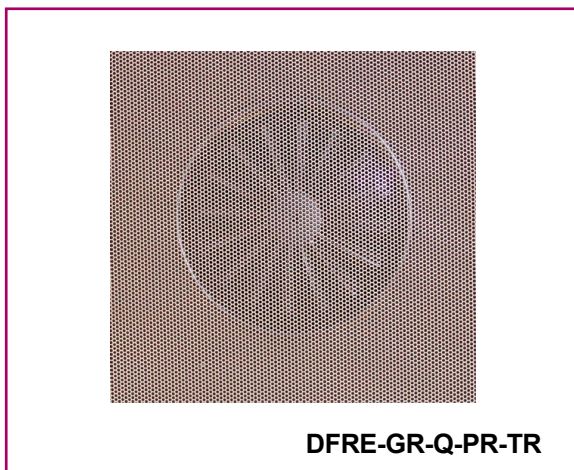

DFRE-GR-PR-TR

The thermoadjustable blade swirl diffuser integrated within a perforated plate has been developed for supply and extract applications. The diffuser consists of a fixed perforated plate or hinged for easy access from the diffuser face, with a thermoadjustable swirl diffuser on the rear.

Manufactured from steel sheet, coated in white RAL 9010. Special finishes available upon request. The plenum box incorporates in the spigot a volume control damper, accessible from the side of the plenum, made of perforated sheet. If required, plenum boxes can be provided with interior insulation.

Models and dimensions: DFRE-GR-TR

DFRE-GR-TR-PCFL-RE

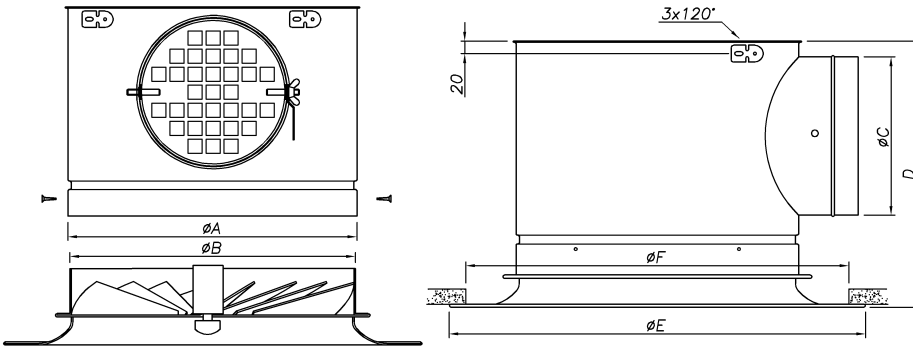

MODEL	A	B	C	D	E	F
160	165	159	124	320	253	228
200	205	199	159	355	303	278
250	255	249	199	395	353	328
315	320	314	249	445	418	393
355	360	354	249	445	458	433
400	405	399	314	510	503	478
500	505	499	314	510	603	578

DFRE-GR-TR-PCDL-RE

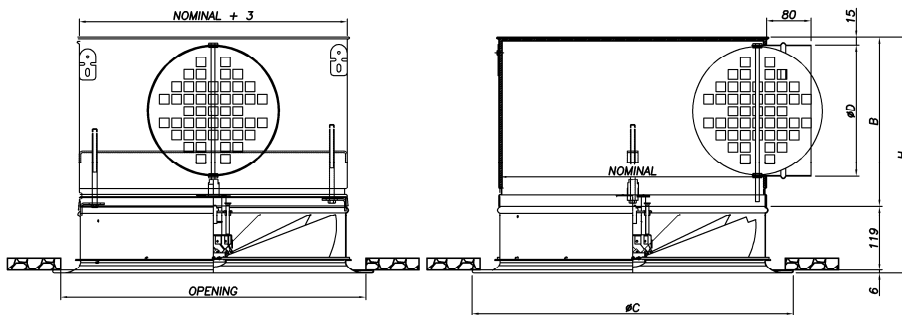

NOMINAL DFRE-GR-TR	HOLE	B	$\varnothing C$	$\varnothing D$	H
160	238	194	253	124	319
200	278	229	303	159	354
250	328	269	353	199	394
315	393	319	418	249	444
350	433	319	458	249	444
400	478	384	503	314	509
500	578	384	503	314	510

Models and dimensions: DFRE-GR-PR-TR

DFRE-GR-PR-TR-PCFL-RE

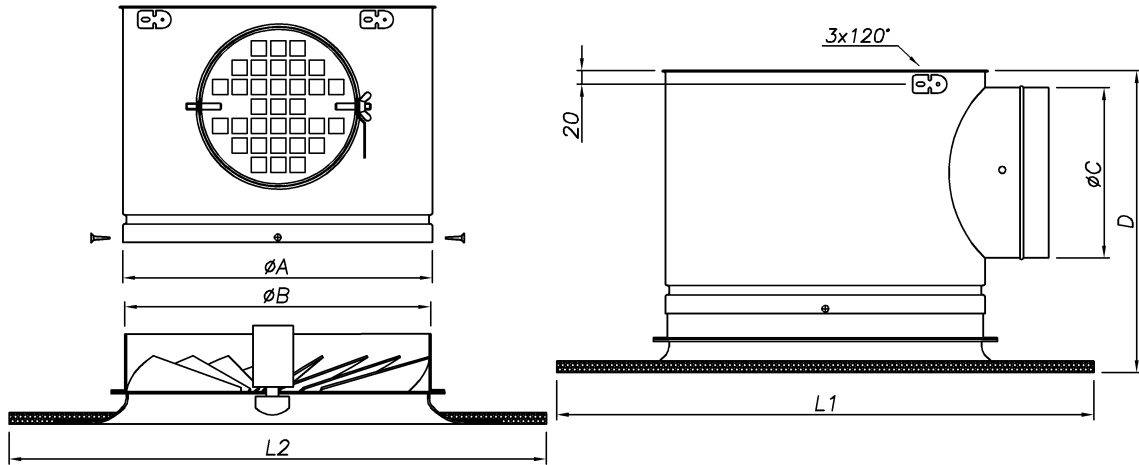

MODEL	DFRE-GR-PR-TR	DFRE-GR-PR-Q-TR	Ø A	Ø B	Ø C	D
	L1 x L2	L1 x L2				
160	594 x 1194	594 x 594	165	159	124	320
200			205	199	159	287
250			255	249	199	327
315			320	314	249	327
355			360	354	249	377
400			405	399	314	377
500			505	499	314	510

Technical data

Photo 1



Photo 2



Photographs of the DFRE-GR-TR tests in R&D Koolair laboratory

The DFRE-GR-TR diffuser includes a component that expands or contracts when the supply air temperature varies, by means of a mechanism that changes the blade position without the need to do this manually. As a result, when hot air is supplied, the thermal component shifts the set of blades upward, causing the air to flow out vertically (Photo 1).

Likewise, when cold air is supplied, the thermal component shifts blades downward, causing the air to flow out horizontally, thereby producing the Coanda or ceiling effect (Photo 2).

The DFRE-GR-TR and DFRE-GR-PR-TR diffusers are ideal for use in high ceilings (from 3.5 to 7 m.), preventing stratification and controlling velocity in the occupied area.

The necessary supply temperature in heat is 28°C.

- Blades position for horizontal discharge at 25°.
- Blades position for vertical discharge at < 90°. It is possible to modify the angle as a function of the vertical throw to reach.
- Sound levels and pressure drop for the execution with plenum side entry.

Technical data. Selection tables

DFRE - GR - TR Horizontal								
Q		Size	200	250	315	355	400	500
(m³/h)	(l/s)	A _k (m²)	0,0114	0,0170	0,0287	0,0338	0,0440	0,0645
100	27,8	V _k (m/s)	2,4					
		X _{gk} (m)	0,8					
		ΔP _t (Pa)	5					
		dB(A)	<20					
150	41,7	V _k (m/s)	3,7	2,4				
		X _{gk} (m)	1,1	0,9				
		ΔP _t (Pa)	11	5				
		dB(A)	26	<20				
200	55,6	V _k (m/s)	4,9	3,3	1,9			
		X _{gk} (m)	1,5	1,2	1,0			
		ΔP _t (Pa)	20	9	3			
		dB(A)	33	24	<20			
300	83,3	V _k (m/s)	7,3	4,9	2,9	2,5		
		X _{gk} (m)	2,3	1,9	1,4	1,3		
		ΔP _t (Pa)	46	20	6	5		
		dB(A)	43	34	21	<20		
400	111,1	V _k (m/s)	9,8	6,5	3,9	3,3	2,5	
		X _{gk} (m)	3,0	2,5	1,9	1,8	1,5	
		ΔP _t (Pa)	81	36	11	9	5	
		dB(A)	50	41	28	<20	<20	
500	138,9	V _k (m/s)		8,2	4,8	4,1	3,2	2,2
		X _{gk} (m)		3,1	2,4	2,2	1,9	1,6
		ΔP _t (Pa)		56	17	14	8	4
		dB(A)		46	34	26	21,8	<20
600	166,7	V _k (m/s)		9,8	5,8	4,9	3,8	2,6
		X _{gk} (m)		3,7	2,9	2,6	2,3	1,9
		ΔP _t (Pa)		81	24	20	12	6
		dB(A)		51	38	31	27	21
750	208,3	V _k (m/s)			7,3	6,2	4,7	3,2
		X _{gk} (m)			3,6	3,3	2,9	2,4
		ΔP _t (Pa)			37	31	19	9
		dB(A)			44	37	33	27
1000	277,8	V _k (m/s)			9,7	8,2	6,3	4,3
		X _{gk} (m)			4,8	4,4	3,8	3,2
		ΔP _t (Pa)			67	55	33	15
		dB(A)			51	45	41	35
1200	333,3	V _k (m/s)				9,9	7,6	5,2
		X _{gk} (m)				5,3	4,6	3,8
		ΔP _t (Pa)				80	48	22
		dB(A)				50	46	40
1400	388,9	V _k (m/s)					8,8	6,0
		X _{gk} (m)					5,4	4,4
		ΔP _t (Pa)					65	30
		dB(A)					50	44
1600	444,4	V _k (m/s)						6,9
		X _{gk} (m)						5,1
		ΔP _t (Pa)						39
		dB(A)						48
1800	500,0	V _k (m/s)						7,8
		X _{gk} (m)						5,7
		ΔP _t (Pa)						50
		dB(A)						51

SYMBOLS	
A _k	Effective area in m ²
V _k	Effective velocity in m/s
X _{gk}	Throw for maximum velocity in occupied area of 0.25 m/s, ΔT= -8 K and an installation height of 3 m, considering Coanda effect, in m
ΔPt	Total pressure drop, in Pa
L _w	Sound power level, in dB(A)

Technical data. Selection graphs

Throw graph

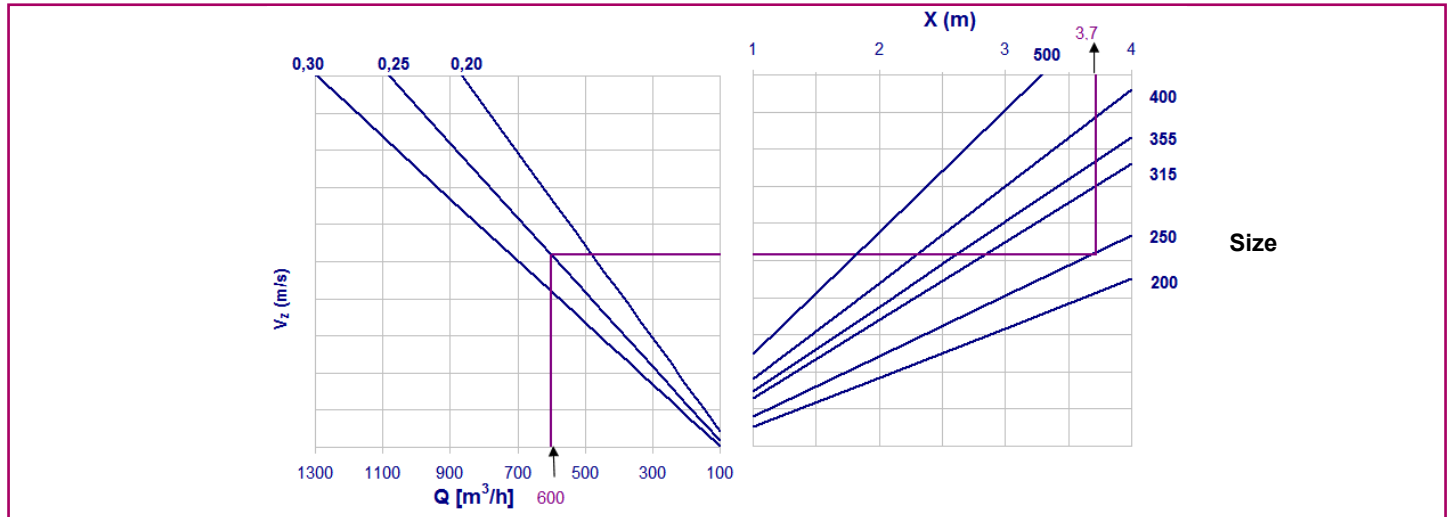

SYMBOLS

- V_z Maximum velocity in occupied area, in m/s
- X Throw in m, for the determined maximum velocity
- Q Airflow, in m^3/h

Induction rate

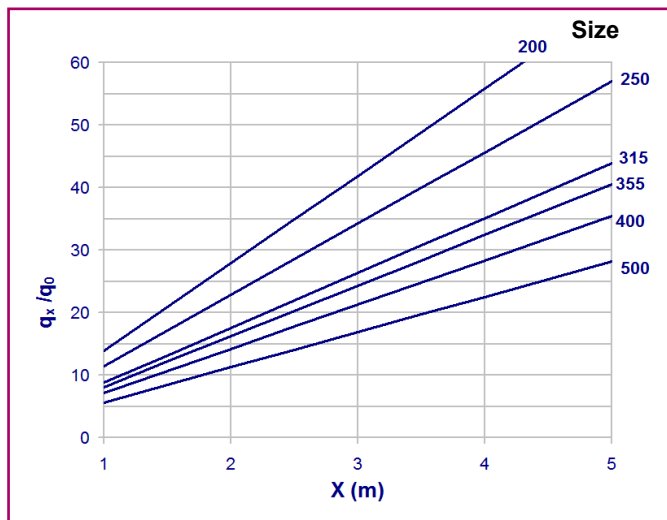

SYMBOLS

- $X(m)$ Distance from the diffuser
- q_0 Air volume in the outlet of the diffuser (primary air)
- q_x Air volume at the distance X from the diffuser

Ratio between temperature

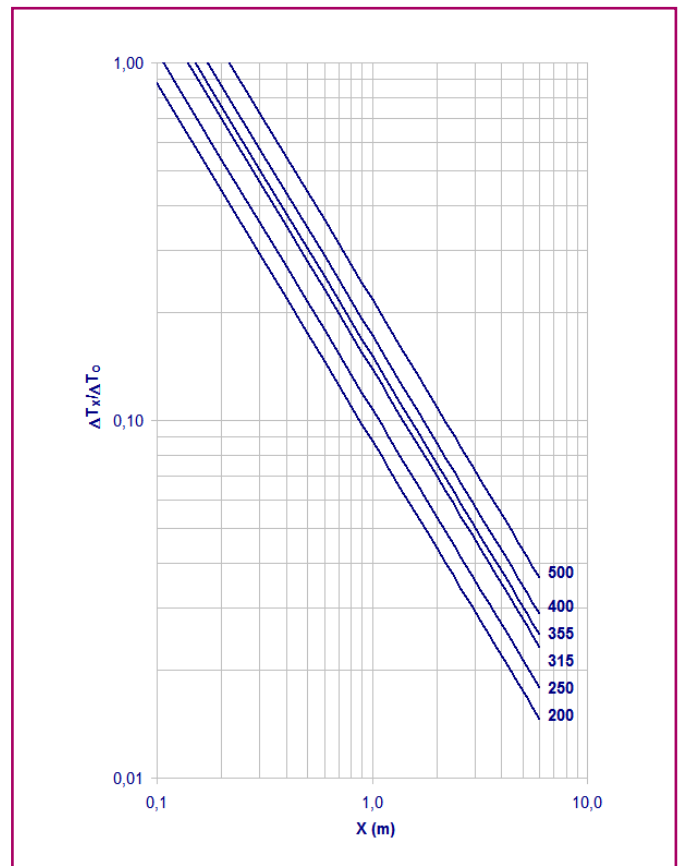

Technical data. Selection tables

DFRE - GR - TR Vertical								
Q		Size	200	250	315	355	400	500
(m ³ /h)	(l/s)	A _k (m ²)	0,0286	0,0447	0,0710	0,0902	0,1145	0,1789
200	55,6	Y _{0,5} (m)	1,1	0,9				
		Y _{0,25} (m)	1,7	1,3				
		V _k (m/s)	1,9	1,2				
		Δp _t (Pa)	4	1				
		dB(A)	<20	<20				
300	83,3	Y _{0,5} (m)	1,7	1,3	1,1	0,9		
		Y _{0,25} (m)	2,5	2,0	1,6	1,4		
		V _k (m/s)	2,9	1,9	1,2	0,9		
		Δp _t (Pa)	8	3	1	1		
		dB(A)	<20	<20	<20	<20		
400	111,1	Y _{0,5} (m)	2,2	1,8	1,4	1,3	1,1	
		Y _{0,25} (m)	3,3	2,7	2,1	1,9	1,6	
		V _k (m/s)	3,9	2,5	1,6	1,2	1,0	
		Δp _t (Pa)	15	5	2	1	1	
		dB(A)	24	<20	<20	<20	<20	
500	138,9	Y _{0,5} (m)	2,8	2,2	1,8	1,6	1,3	1,0
		Y _{0,25} (m)	4,2	3,3	2,7	2,4	2,0	1,5
		V _k (m/s)	4,9	3,1	2,0	1,5	1,2	0,8
		Δp _t (Pa)	23	8	3	2	1	0
		dB(A)	31	<20	<20	<20	<20	<20
600	166,7	Y _{0,5} (m)	3,3	2,7	2,1	1,9	1,6	1,2
		Y _{0,25} (m)	5,0	4,0	3,2	2,8	2,4	1,8
		V _k (m/s)	5,8	3,7	2,3	1,8	1,5	0,9
		Δp _t (Pa)	33	12	4	2	2	1
		dB(A)	37	25	<20	<20	<20	<20
750	208,3	Y _{0,5} (m)	4,2	3,3	2,7	2,4	2,0	1,5
		Y _{0,25} (m)	6,3	5,0	4,0	3,5	3,0	2,2
		V _k (m/s)	7,3	4,7	2,9	2,3	1,8	1,2
		Δp _t (Pa)	52	19	6	4	2	1
		dB(A)	44	32	<20	<20	<20	<20
1000	277,8	Y _{0,5} (m)		4,5	3,5	3,1	2,6	2,0
		Y _{0,25} (m)		6,7	5,3	4,7	3,9	3,0
		V _k (m/s)		6,2	3,9	3,1	2,4	1,6
		Δp _t (Pa)		34	11	7	4	2
		dB(A)		41	24	<20	<20	<20
1500	416,7	Y _{0,5} (m)			5,3	4,7	3,9	3,0
		Y _{0,25} (m)			8,0	7,1	5,9	4,4
		V _k (m/s)			5,9	4,6	3,6	2,3
		Δp _t (Pa)			25	15	10	4
		dB(A)			36	30	24	<20
2000	555,6	Y _{0,5} (m)			7,1	6,3	5,3	3,9
		Y _{0,25} (m)			10,6	9,4	7,9	5,9
		V _k (m/s)			7,8	6,2	4,9	3,1
		Δp _t (Pa)			44	27	17	7
		dB(A)			45	39	33	21
2500	694,4	Y _{0,5} (m)				7,9	6,6	4,9
		Y _{0,25} (m)				11,8	9,9	7,4
		V _k (m/s)				7,7	6,1	3,9
		Δp _t (Pa)				43	26	11
		dB(A)				46	40	28
3000	833,3	Y _{0,5} (m)					7,9	5,9
		Y _{0,25} (m)					11,8	8,9
		V _k (m/s)					7,3	4,7
		Δp _t (Pa)					38	16
		dB(A)					45	34
4000	1111,1	Y _{0,5} (m)						7,9
		Y _{0,25} (m)						11,8
		V _k (m/s)						6,2
		Δp _t (Pa)						28
		dB(A)						43

SYMBOLS

A_k Effective area in m²
V_k Effective velocity in m/s
Y_{0,5} Vertical penetration for a velocity of 0,5 m/s, ΔT= 8 K
Y_{0,25} Vertical penetration for a velocity of 0,25 m/s, ΔT= 8 K
ΔP_t Total pressure drop in Pa
L_w Sound power level in dB(A)

Technical data. Selection graphs

Maximum vertical penetration graph

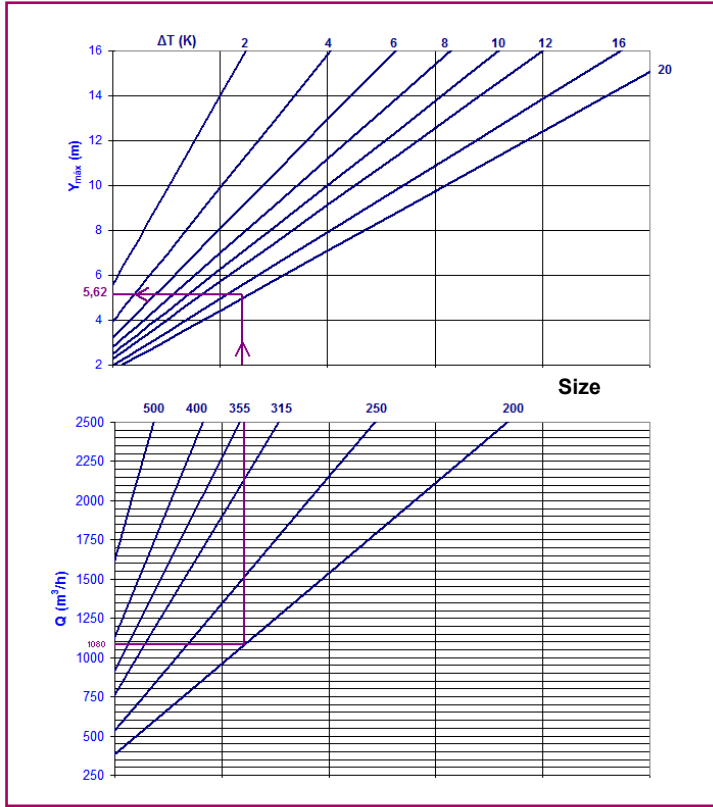

SYMBOLS

- ΔT Difference temperature
- Y Maximal vertical penetration in m
- $Q =$ Airflow, in m^3/h

$Y\sigma = Y * C$

Blade angle (σ)	90°	75°	60°	45°
C	1	0,85	0,7	0,55

Correction factor (C) for vertical penetration at different blade angle.

SYMBOLS

- $X(m)$ Distance from the diffuser
- q_0 Air volume in the outlet of the diffuser (primary air)
- q_x Air volume at the distance X from the diffuser

Induction rate

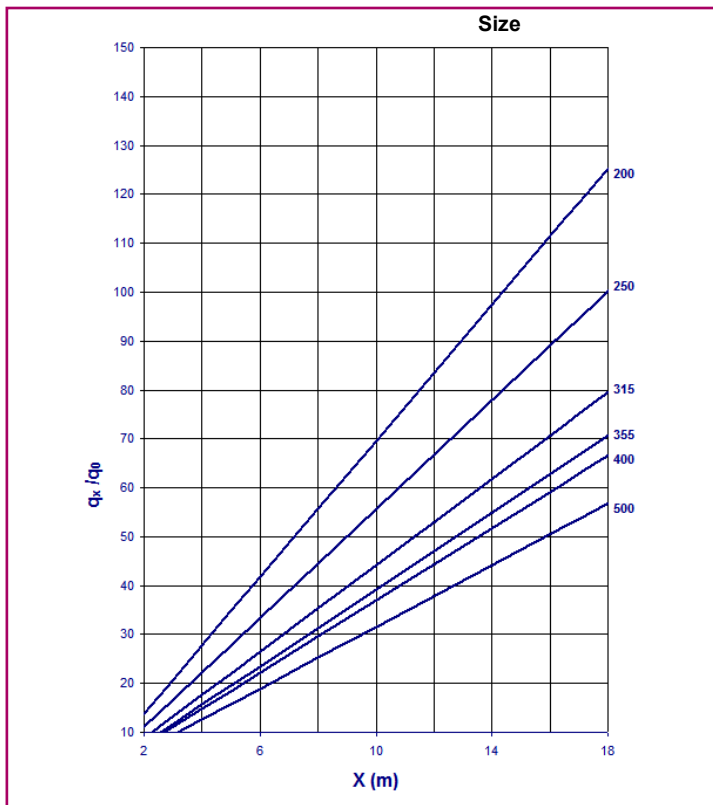

Ratio between temperature differences

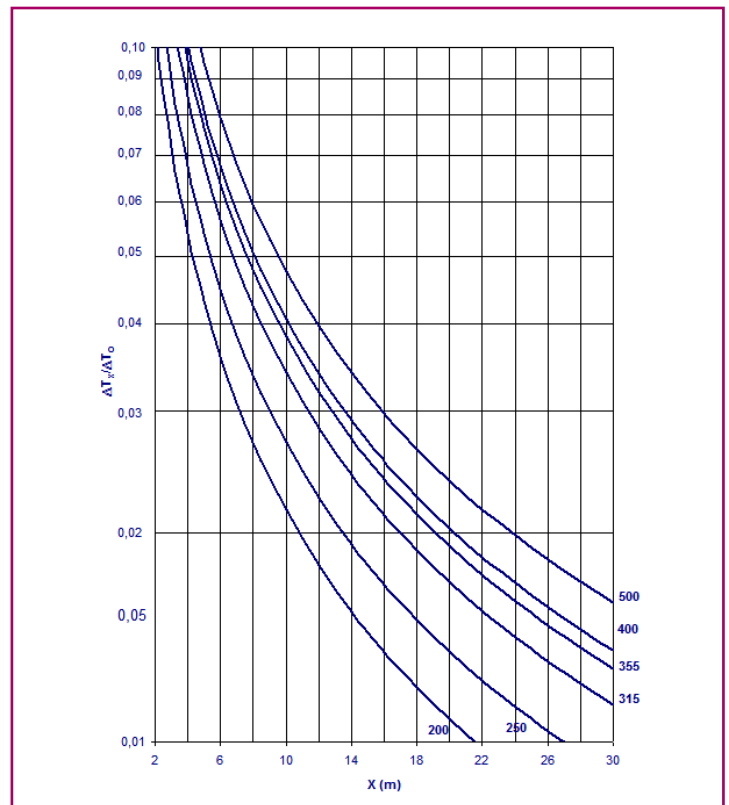

Product code

The product code shown below is used to define both the diffuser as well as the plenum:

DFRE-GR-TR	Thermo-adjustable blade swirl diffuser
DFRE-GR-PR-TR	Thermo-adjustable blade swirl diffuser integrated in a perforated plate
DFRE-GR-TR-Q	Thermo-adjustable blade swirl diffuser in plate size 594 x 594 mm for false ceiling
DFRE-GR-C-PR-TR	Thermo-adjustable blade swirl diffuser integrated in a circular perforated plate
DF-RE-GR-RM.	Adjustable blade steel sheet swirl diffuser with manual regulation.
DF-RE-GR-RM-Q.	Adjustable blade swirl diffuser in plate size 594 x 594 for false ceiling, with manual regulation.
DFRE-GR-MT	Adjustable blade swirl diffuser with electric actuator T/N (24v or 230v). Available from Ø315 to Ø500.
DFRE-GR-MT-Q	Adjustable blade swirl diffuser with electric actuator T/N (24v or 230v), in 595x595 mm plate for installation in modular false ceilings. Available from Ø315 to Ø500.
Ø (200...500)	Size
PCFL.	Circular fixed plenum box with side connection.
PCDL.	Circular removable plenum box with side connection.
A.	insulated
RE.	with manual damper accesible from false ceiling.
RAL	Special finishes available upon request

Example:

DFRE-GR-TR-Ø315 RAL 9010

Thermoadjustable blade swirl diffuser, size 315 mm coated in white RAL 9010.

THIS CATALOGUE IS INTELLECTUAL PROPERTY.

Reproduction, either partial or total, by any means, including electronic, is prohibited without prior written authorisation from KOOLAIR, S.L.



KOOLAIR

KOOLAIR, S.L.

Calle Urano, 26

Poligono industrial nº 2 – La Fuensanta

28936 Móstoles - Madrid - (España)

Tel: +34 91 645 00 33

Fax: +34 91 645 69 62

e-mail: info@koolair.com

www.koolair.com