

# KOOLAIR

## series

# DTP

## Multi-nozzles diffusers

ISO 9001

BUREAU VERITAS  
Certification

Sistema de Gestión



[www.koolair.com](http://www.koolair.com)

## Multi-nozzles Diffuser

### CONTENTS

Introduction	4
Models and dimensions	5
Selection tables	9
Product code	13

## Multi-nozzles Diffuser

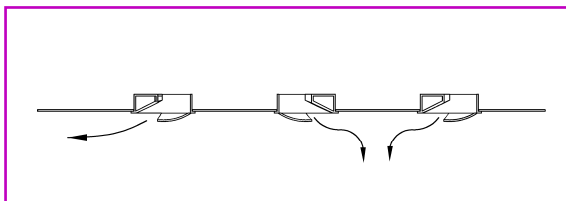
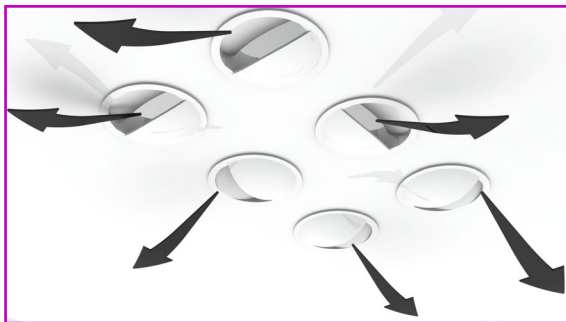
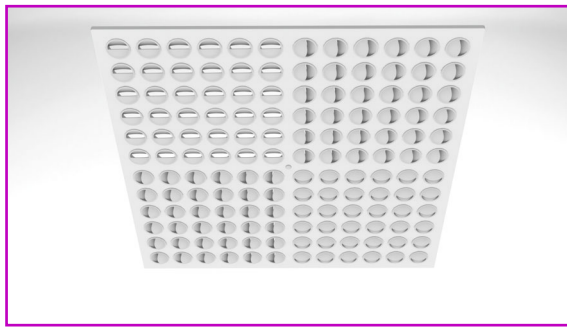
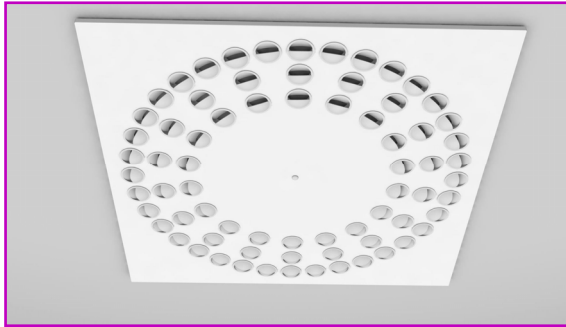

### Description

The DTP, multi-nozzles diffuser is designed to solve any diffusion problem, either conventional or specific, capable of being adapted to the multiple and different problems generated by a right air diffusion installation. We are facing a versatile product with a different aesthetic and interior design needs, with low noise and excellent performance in the air diffusion.

Composed of small nozzles individually adjustable in all directions. The fact of being adjustable, allows to adjust them on site, solving those little situations that sometimes occur, in which the excess or lack of air in certain areas can cause problems.

Meet the following requirements:

- High degree of air diffusion in any direction.
- Suitable for installations with constant and variable air-flow.
- Can be used for both cold and hot air (horizontal or vertical flow).
- Low noise level.
- Flexible integration into any décor or interior design.
- Ability to modify and adjust work multiple orientations of the air stream, radial, linear, rotational, vertical.

### Application

Its integration into a false ceiling makes it particularly suitable for office buildings, hotels, restaurants, showrooms, banks, libraries, etc. Can also be installed in ducts, decorative plenums, walls, floor or sill windows.

The performance is similar to a linear diffuser with horizontal flow, producing the "Coanda effect" maintaining a smooth flow and high induction rate.

To obtain simply vertical airflow, just face two or more nozzles.

### Finish

Multi-nozzles made of ABS plastic in white-VO and steel plate. Standard finish in RAL 9010 gloss.

Plenum box in galvanized steel sheet, equipped with internal equalizer to ensure proper air distribution and inlet standard diameter ISO, with manual regulating damper.

There is also the possibility of incorporating an electric actuator for VAV system applications.

Other special finishes can be supplied on request and after consultation with our sales department.

## Models and dimensions: DTP-Q / DTP

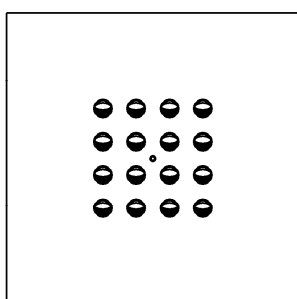
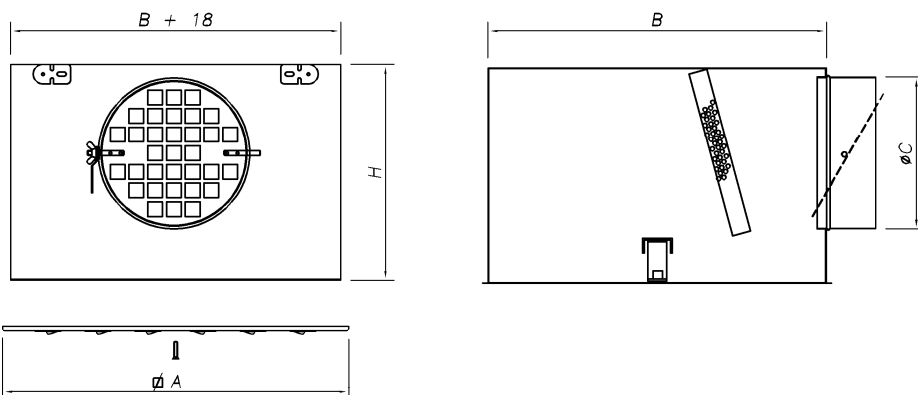

DTP-Q-16

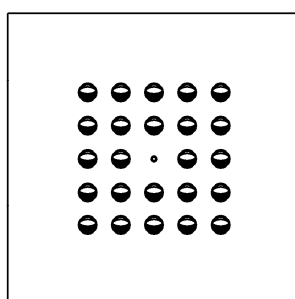

DTP-Q-24

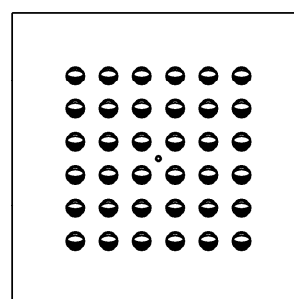

DTP-Q-36

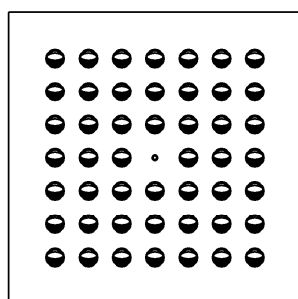

DTP-Q-48

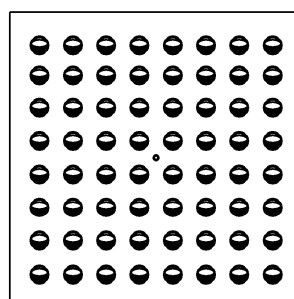

DTP-Q-64

MODEL	A	B	Ø D	H
DTP-Q-16	594	270	125	225
DTP-Q-24	594	350	125	225
DTP-Q-36	594	410	160	250
DTP-Q-48	594	488	200	300
DTP-Q-64	594	550	200	300
DTP-16	594	270	125	225
DTP-24	444	350	125	225
DTP-36	494	410	160	250
DTP-48	554	488	200	300
DTP-64	594	550	200	300

Fixing the diffuser to the plenum is made by a single central screw, in the case of removable plenum (dimensions shown).

## Models and dimensions: DTP-C-Q / DTP-PR

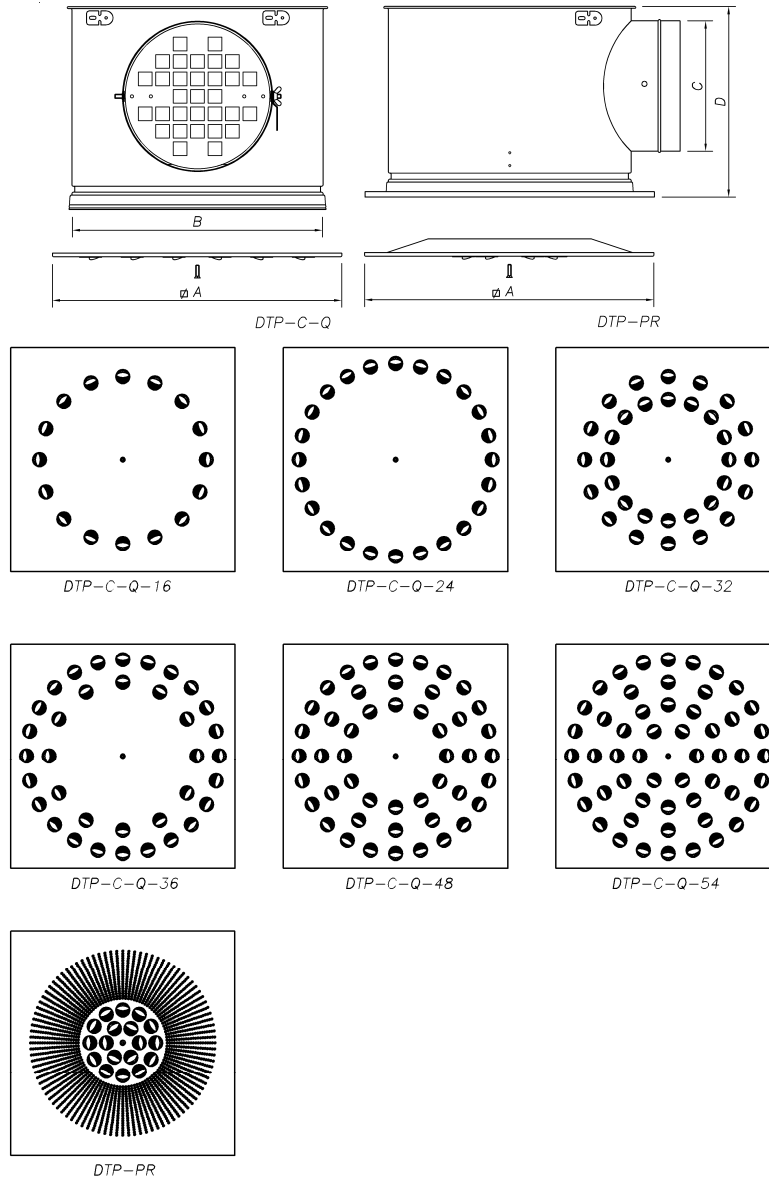

MODEL	A	Ø B	Ø D	H
DTP-C-Q-16	594	580	125	200
DTP-C-Q-24	594	580	125	200
DTP-C-Q-32	594	580	160	235
DTP-C-Q-36	594	580	160	235
DTP-C-Q-48	594	580	200	275
DTP-C-Q-54	594	580	200	275
DTP-PR	594	580	200	275

Fixing the diffuser to the plenum is made by a single central screw, in the case of removable plenum (dimensions shown).

## Models and dimensions: DTP-C / DTP-PR-C

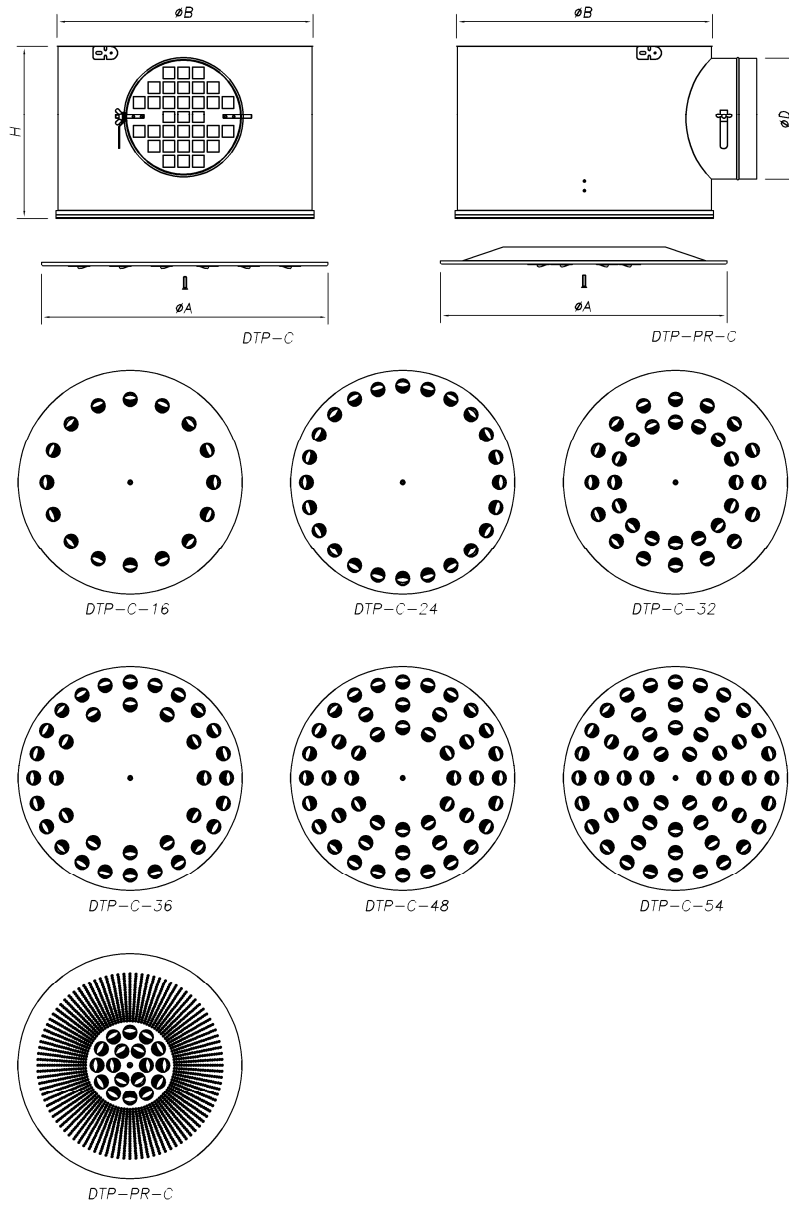

MODEL	Ø A	Ø B	Ø D	H
DTP-C-16	594	576	125	192
DTP-C-24	594	576	125	492
DTP-C-32	594	576	160	227
DTP-C-36	594	576	160	227
DTP-C-48	594	576	200	267
DTP-C-54	594	576	200	267
DTP-PR-C	594	576	200	267

Fixing the diffuser to the plenum is made by a single central screw, in the case of removable plenum (dimensions shown).

Models and dimensions: DTP-L

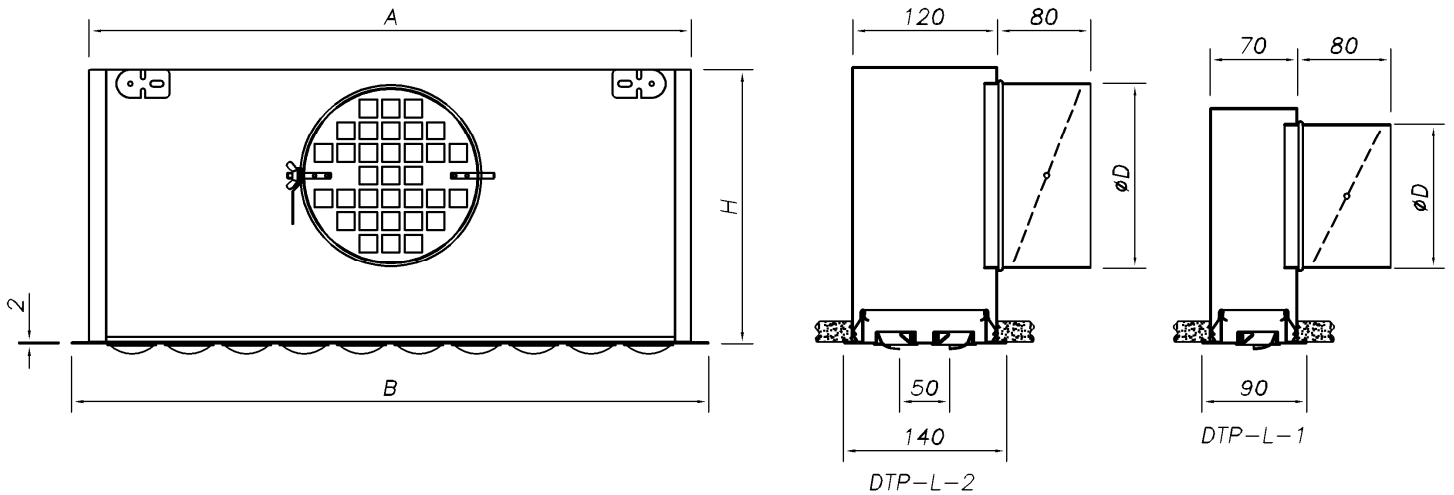

DTP-L-1-18



DTP-L-1-20

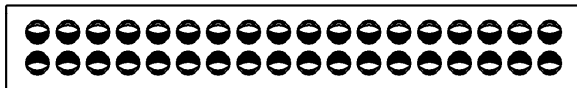

DTP-L-2-18

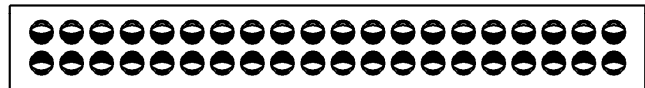

DTP-L-2-20

MODEL	A	B	Ø D	H
DTP-L-1-18	910	940	125	195
DTP-L-2-18	910	940	160	230
DTP-L-1-20	1010	1040	125	195
DTP-L-2-20	1010	1040	160	230
DTP-L-1-24	1210	1240	125	195
DTP-L-2-24	1210	1240	160	230
DTP-L-1-30	1510	1540	160	230
DTP-L-2-30	1510	1540	200	270
DTP-L-1-36	1810	1840	160	230
DTP-L-2-36	1810	1840	200	270

Fixing the diffuser to the plenum is made by mounting clips, in the case of removable plenum (dimensions shown). There is also the possibility of fixed plenum (for dimensions see the sales department).

## Selection tables: DTP / DTP-Q

DTP / DTP-Q (1 direction)							
Q		Model	16	25	36	48	64
m <sup>3</sup> /h	l/s						
50	13,9	V <sub>k</sub>	3,9	2,5			
		X	2,5	1,0			
		ΔP <sub>t</sub>	12	6			
		L <sub>WA</sub>	<15	<15			
80	22,2	V <sub>k</sub>	6,3	4,0	2,8		
		X	3,9	3,2	2,6		
		ΔP <sub>t</sub>	32	16	8		
		L <sub>WA</sub>	19	<15	<15		
100	27,8	V <sub>k</sub>	7,9	5,1	3,5	2,6	
		X	4,9	3,9	3,3	2,8	
		ΔP <sub>t</sub>	50	25	12	5	
		L <sub>WA</sub>	26	16	<15	<15	
125	34,7	V <sub>k</sub>	9,9	6,3	4,4	3,2	2,5
		X	6,2	4,9	4,1	3,5	3,1
		ΔP <sub>t</sub>	78	40	19	9	3
		L <sub>WA</sub>	33	23	15	<15	<15
150	41,7	V <sub>k</sub>	11,8	7,6	5,3	3,9	2,0
		X	7,4	5,9	4,9	4,2	3,7
		ΔP <sub>t</sub>	113	58	28	13	4
		L <sub>WA</sub>	39	29	21	<15	<15
175	48,6	V <sub>k</sub>		8,8	6,1	4,5	3,5
		X		6,9	5,7	4,9	4,3
		ΔP <sub>t</sub>		79	38	17	6
		L <sub>WA</sub>		34	26	19	<15
200	55,6	V <sub>k</sub>		10,1	7,0	5,2	3,9
		X		7,9	6,6	5,6	4,9
		ΔP <sub>t</sub>		103	50	23	8
		L <sub>WA</sub>		38	30	23	18
250	69,4	V <sub>k</sub>			8,8	6,4	4,9
		X			8,2	7,0	6,2
		ΔP <sub>t</sub>			79	36	13
		L <sub>WA</sub>			37	30	25
300	83,3	V <sub>k</sub>			10,5	7,7	5,9
		X			9,9	8,4	7,4
		ΔP <sub>t</sub>			114	52	18
		L <sub>WA</sub>			43	36	30
350	97,2	V <sub>k</sub>				9,0	6,9
		X				9,9	8,6
		ΔP <sub>t</sub>				71	25
		L <sub>WA</sub>				41	35
400	111,1	V <sub>k</sub>				10,3	7,9
		X				11,3	9,9
		ΔP <sub>t</sub>				93	33
		L <sub>WA</sub>				45	39
500	138,9	V <sub>k</sub>					9,9
		X					12,3
		ΔP <sub>t</sub>					52
		L <sub>WA</sub>					47
600	166,7	V <sub>k</sub>					11,8
		X					14,8
		ΔP <sub>t</sub>					75
		L <sub>WA</sub>					52

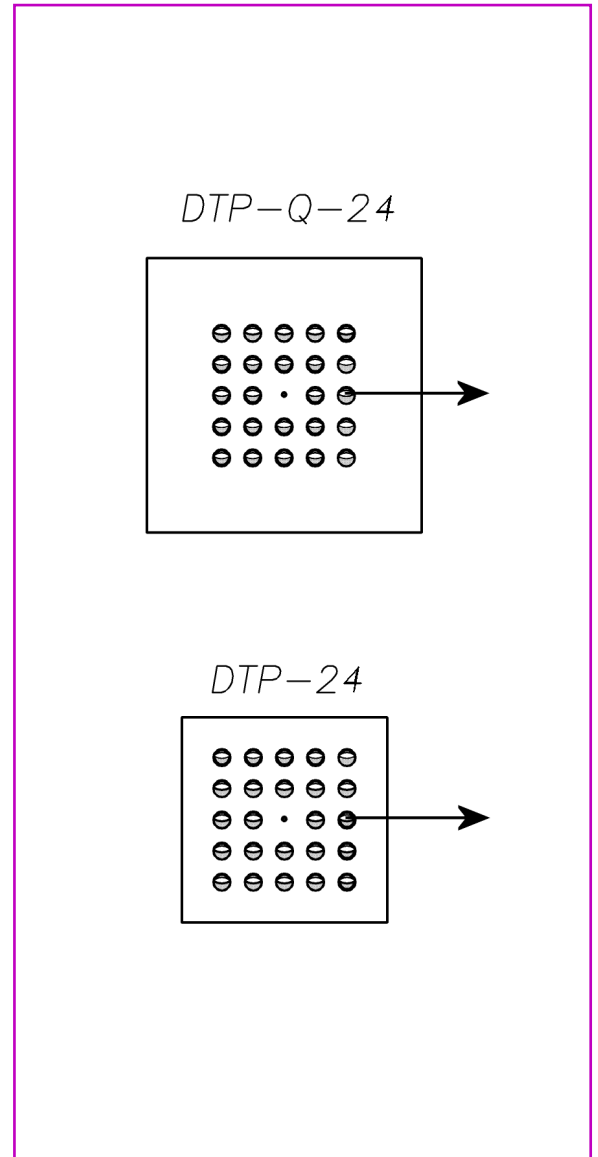

**SYMBOLS**

V<sub>k</sub> Effective velocity in m/s  
 X Throw for maximum velocity in occupied area of 0,25 m/s, ΔT= 0 K and an installation height of 3 m, considering Coanda effect, in m  
 P<sub>t</sub> Total pressure drop, in Pa  
 L<sub>WA</sub> Sound power level, in dB(A)



## Selection tables: DTP / DTP-Q

DTP / DTP-Q (2 directions)					
Q		Model	16	36	64
m³/h	l/s				
50	13,9	V <sub>k</sub>	2,8	1,2	
		X	1,7	1,1	
		ΔP <sub>t</sub>	12	3	
		L <sub>WA</sub>	<15	<15	
80	22,2	V <sub>k</sub>	4,4	1,0	
		X	2,8	1,8	
		ΔP <sub>t</sub>	32	8	
		L <sub>WA</sub>	19	<15	
100	27,8	V <sub>k</sub>	5,5	2,5	1,4
		X	3,4	2,3	1,7
		ΔP <sub>t</sub>	50	12	2
		L <sub>WA</sub>	26	<15	<15
125	34,7	V <sub>k</sub>	6,9	3,1	1,7
		X	4,3	2,9	2,2
		ΔP <sub>t</sub>	78	19	3
		L <sub>WA</sub>	33	15	<15
150	41,7	V <sub>k</sub>	8,3	3,7	2,1
		X	5,2	3,4	2,6
		ΔP <sub>t</sub>	113	28	4
		L <sub>WA</sub>	39	21	<15
175	48,6	V <sub>k</sub>	9,7	4,3	2,4
		X	6,0	4,0	3,0
		ΔP <sub>t</sub>	153	38	6
		L <sub>WA</sub>	44	26	<15
200	55,6	V <sub>k</sub>		4,9	2,8
		X		4,6	3,4
		ΔP <sub>t</sub>		50	8
		L <sub>WA</sub>		30	18
250	69,4	V <sub>k</sub>		6,1	3,5
		X		5,7	4,3
		ΔP <sub>t</sub>		79	13
		L <sub>WA</sub>		37	25
300	83,3	V <sub>k</sub>		7,4	4,1
		X		6,9	5,2
		ΔP <sub>t</sub>		114	18
		L <sub>WA</sub>		43	30
350	97,2	V <sub>k</sub>		8,6	4,8
		X		8,0	6,0
		ΔP <sub>t</sub>		155	25
		L <sub>WA</sub>		48	35
400	111,1	V <sub>k</sub>			5,5
		X			6,9
		ΔP <sub>t</sub>			33
		L <sub>WA</sub>			39
500	138,9	V <sub>k</sub>			6,9
		X			8,6
		ΔP <sub>t</sub>			52
		L <sub>WA</sub>			47
600	166,7	V <sub>k</sub>			8,3
		X			10,3
		ΔP <sub>t</sub>			75
		L <sub>WA</sub>			52

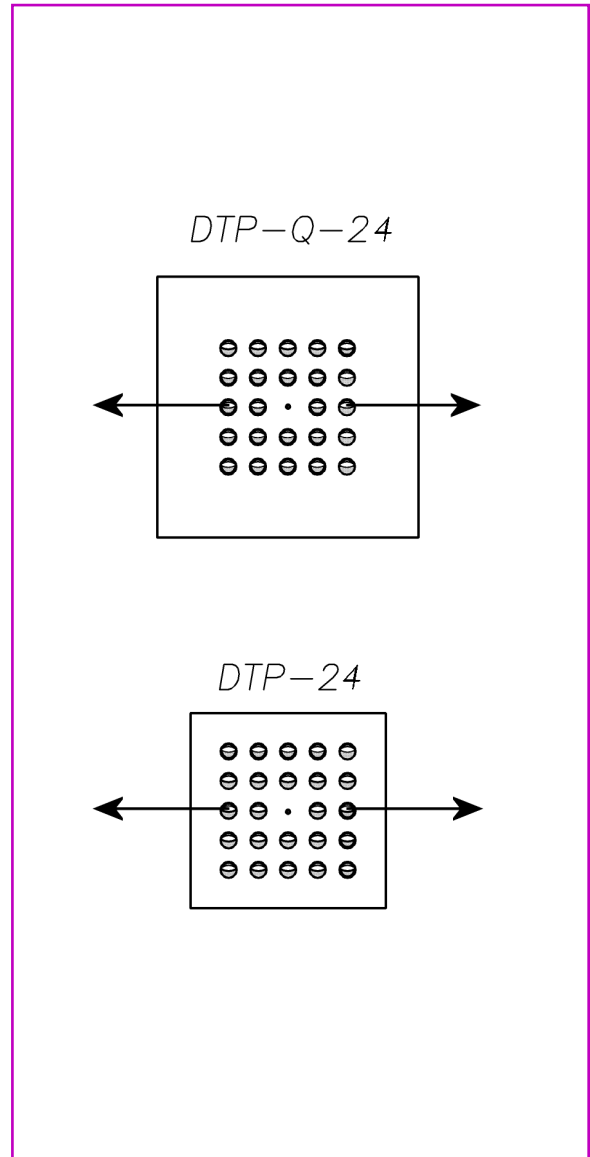

### SYMBOLS

- V<sub>k</sub> Effective velocity in m/s
- X Throw for maximum velocity in occupied area of 0,25 m/s, ΔT= 0 K and an installation height of 3 m, considering Coanda effect, in m
- P<sub>t</sub> Total pressure drop, in Pa
- L<sub>WA</sub> Sound power level, in dB(A)

## Selection tables: DTP-C / DTP-C-Q / DTP-PR

Q		DTP-C / DTP-C-Q							DTP-PR	
m <sup>3</sup> /h	l/s	Model	16	24	32	36	48	54		
50	13,9	V <sub>k</sub>	3,9	2,6						
		X	1,5	1,2						
		ΔP <sub>t</sub>	15	7						
		L <sub>WA</sub>	22	<15						
80	22,2	V <sub>k</sub>	6,3	4,2	3,2	2,8				
		X	2,4	1,9	1,7	1,6				
		ΔP <sub>t</sub>	38	18	10	8				
		L <sub>WA</sub>	35	23	<15	<15				
100	27,8	V <sub>k</sub>	7,9	5,3	3,9	3,5	2,6			
		X	2,0	2,4	2,1	1,0	1,7			
		ΔP <sub>t</sub>	60	28	15	12	7			
		L <sub>WA</sub>	41	29	20	17	<15			
125	34,7	V <sub>k</sub>	9,9	6,6	4,9	4,4	3,3	2,9		
		X	3,7	3,0	2,6	2,5	2,1	2,0		
		ΔP <sub>t</sub>	93	44	24	19	11	9		
		L <sub>WA</sub>	47	35	26	23	<15	<15		
150	41,7	V <sub>k</sub>	11,8	7,9	5,9	5,3	3,9	3,5		
		X	4,4	3,6	3,1	2,0	2,6	2,4		
		ΔP <sub>t</sub>	135	63	35	28	16	14		
		L <sub>WA</sub>	52	40	31	28	19	16		
175	48,6	V <sub>k</sub>		9,2	6,9	6,1	4,6	4,1	1,4	
		X		4,2	3,7	3,4	2,0	2,8	1	
		ΔP <sub>t</sub>		87	47	39	22	19	6,2	
		L <sub>WA</sub>		44	36	32	24	22	<15	
200	55,6	V <sub>k</sub>		10,5	7,9	7,0	5,3	4,7	1,6	
		X		4,8	4,2	3,9	3,4	3,2	1,2	
		ΔP <sub>t</sub>		113	62	51	29	25	8	
		L <sub>WA</sub>		48	39	36	29	26	21	
250	69,4	V <sub>k</sub>		9,9	8,8	6,6	5,8	2		
		X		5,2	4,9	4,3	4,0	1,5		
		ΔP <sub>t</sub>		97	79	46	39	13		
		L <sub>WA</sub>		45	42	36	34	27		
300	83,3	V <sub>k</sub>			11,8	10,5	7,9	7,0	2,4	
		X			6,3	5,9	5,1	4,8	1,8	
		ΔP <sub>t</sub>			140	115	67	56	18	
		L <sub>WA</sub>			50	47	43	40	32	
350	97,2	V <sub>k</sub>				12,3	9,2	8,2	2,7	
		X				6,9	5,0	5,6	2,1	
		ΔP <sub>t</sub>				156	91	76	25	
		L <sub>WA</sub>				51	48	46	37	
400	111,1	V <sub>k</sub>					10,5	9,4	3,1	
		X					6,8	6,4	2,4	
		ΔP <sub>t</sub>					119	100	32	
		L <sub>WA</sub>					53	50	40	
500	138,9	V <sub>k</sub>						11,7	3,9	
		X						8,0	3	
		ΔP <sub>t</sub>							157	51
		L <sub>WA</sub>							58	47

DTP-C-Q-32

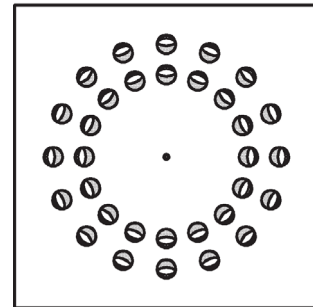

DTP-C-32

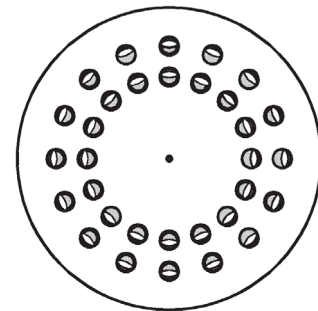

DTP-PR-C

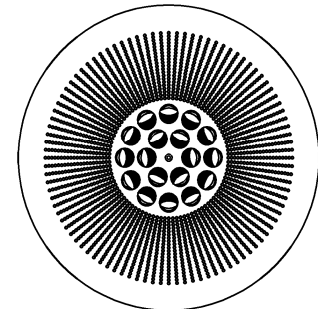

### SYMBOLS

- V<sub>k</sub> Effective velocity in m/s
- X Throw for maximum velocity in occupied area of 0,25 m/s, ΔT= 0 K and an installation height of 3 m, considering Coanda effect, in m
- P<sub>t</sub> Total pressure drop, in Pa
- L<sub>WA</sub> Sound power level, in dB(A)

## Selection tables: DTP-L

DTP - L (1 direction)								
Q		Modelo (coding)	1000-1 (1-20)	1200-1 (1-24)	1500-1 (1-30)	1000-2 (2-20)	1200-2 (2-24)	1500-2 (2-30)
m³/h	l/s							
50	13,9	V <sub>k</sub>	3,2	2,6	2,1			
		X	2,2	2,0	1,8			
		ΔP <sub>t</sub>	9	6	4			
		L <sub>WA</sub>	<15	<15	<15			
80	22,2	V <sub>k</sub>	5,1	4,2	3,4	2,5	2,1	
		X	3,5	3,2	2,9	2,5	2,3	
		ΔP <sub>t</sub>	23	17	11	6	4	
		L <sub>WA</sub>	<15	<15	<15	<15	<15	
100	27,8	V <sub>k</sub>	6,3	5,3	4,2	3,2	2,6	2,1
		X	4,4	4,0	3,6	3,1	2,8	2,5
		ΔP <sub>t</sub>	36	27	17	10	6	2
		L <sub>WA</sub>	21	17	<15	<15	<15	<15
125	34,7	V <sub>k</sub>	7,9	6,6	5,3	3,9	3,3	2,6
		X	5,5	5,0	4,5	3,9	3,6	3,2
		ΔP <sub>t</sub>	56	43	27	16	10	4
		L <sub>WA</sub>	28	24	19	<15	<15	<15
150	41,7	V <sub>k</sub>	9,5	7,9	6,3	4,7	3,9	3,2
		X	6,6	6,0	5,4	4,7	4,3	3,8
		ΔP <sub>t</sub>	81	62	39	23	15	6
		L <sub>WA</sub>	34	30	25	19	15	<15
175	48,6	V <sub>k</sub>	11,0	9,2	7,4	5,5	4,6	3,7
		X	7,7	7,0	6,3	5,5	4,0	4,5
		ΔP <sub>t</sub>	110	84	54	31	20	8
		L <sub>WA</sub>	39	35	30	24	20	15
200	55,6	V <sub>k</sub>	12,6	10,5	8,4	6,3	5,3	4,2
		X	8,8	8,0	7,2	6,2	5,7	5,1
		ΔP <sub>t</sub>	144	110	70	41	27	11
		L <sub>WA</sub>	43	39	34	28	24	19
250	69,4	V <sub>k</sub>		13,2	10,5	7,9	6,6	5,3
		X		10,1	8,0	7,8	7,1	6,4
		ΔP <sub>t</sub>		172	110	64	42	18
		L <sub>WA</sub>		46	41	35	31	26
300	83,3	V <sub>k</sub>			12,6	9,5	7,9	6,3
		X			10,8	9,4	8,5	7,6
		ΔP <sub>t</sub>			159	92	61	25
		L <sub>WA</sub>			47	41	37	32
350	97,2	V <sub>k</sub>				11,0	9,2	7,4
		X				10,9	9,0	8,9
		ΔP <sub>t</sub>				126	83	35
		L <sub>WA</sub>				46	42	37
400	111,1	V <sub>k</sub>					10,5	8,4
		X					11,4	10,2
		ΔP <sub>t</sub>					109	46
		L <sub>WA</sub>					46	41
500	138,9	V <sub>k</sub>						10,5
		X						12,7
		ΔP <sub>t</sub>						72
		L <sub>WA</sub>						48
600	166,7	V <sub>k</sub>						12,6
		X						15,3
		ΔP <sub>t</sub>						103
		L <sub>WA</sub>						54

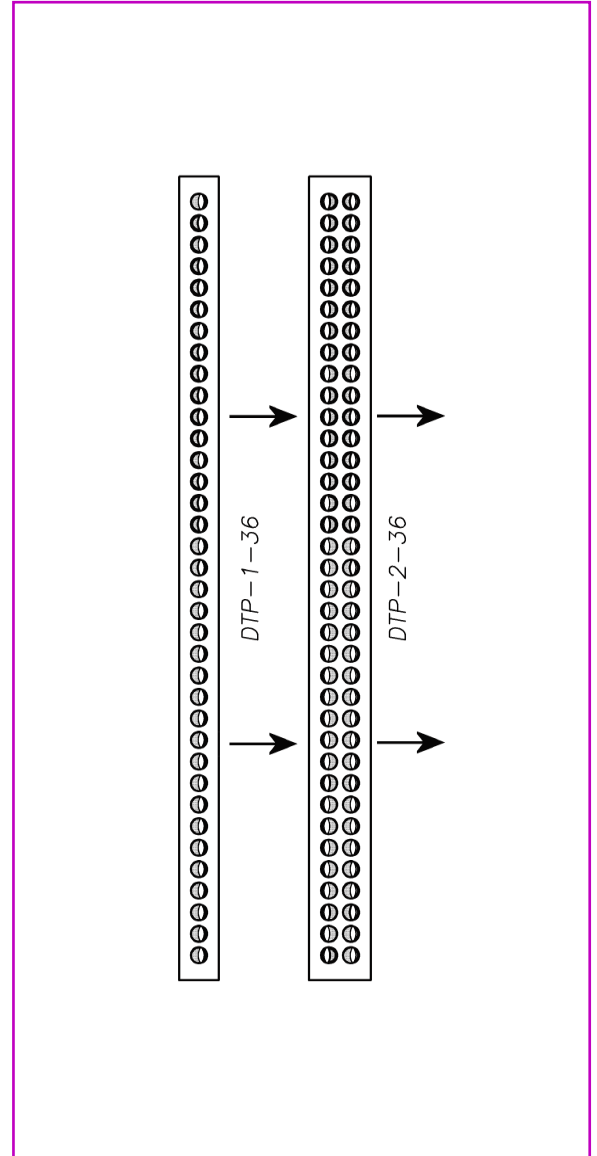

### SYMBOLS

- V<sub>k</sub> Effective velocity in m/s
- X Throw for maximum velocity in occupied area of 0,25 m/s, ΔT= 0 K and an installation height of 3 m, considering Coanda effect, in m
- P<sub>t</sub> Total pressure drop, in Pa
- L<sub>WA</sub> Sound power level, in dB(A)

## Product code

The product code shown below is used to define both the diffuser as well as the plenum:

DTP	Multi-nozzles diffuser
---	Square platte
Q	Square platte 594 x 594
C	Circular platte
L	Linear
C-Q	Square platte 594 x 594 in circular distribution
PR	Square platte 594 x 594 with perforated plate
PR-C	Circular platte with perforated plate
1	One direction
2	Two directions
3	Three directions
4	Four directions
R	Radial
---	No. Nozzles
---	Without plenum
PF	Fixed plenum without damper
PD	Removable plenum without damper
PF-C	Fixed plenum with damper
PD-C	Removable plenum with damper
PFA	Insulated fixed plenum without damper
PDA	Insulated removable plenum without damper
PFA-C	Insulated fixed plenum with damper
PDA-C	Insulated removable plenum with damper
PM	Mounting bridge for diffuser without plenum
PZ	Mounting bridge for diffuser for plenum
RAL 9010	Standard finished product in white
RAL...	Finished product in another RAL coating

### Technical specifications:

DTP-C-R- 54-PFA-C RAL 9010

Multi-nozzles diffuser in circular platte comprises of 54 nozzles with insulated fixed plenum with damper painted in white RAL 9010.

Other possibilities:

Easily integrated into the decor, the nozzles can be installed in different executions.

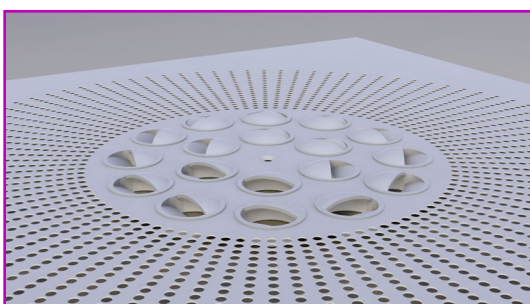

DTP-PR

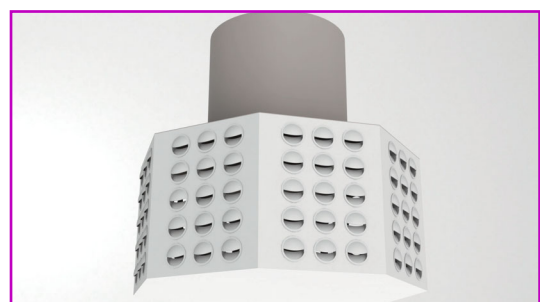

DTP-TOTEM

**THIS CATALOGUE IS INTELLECTUAL PROPERTY.**

Reproduction, either partial or total, by any means, including electronic, is prohibited without prior written authorisation from KOOLAIR, S.L.



**KOOLAIR, S.L.**

Calle Urano, 26

Poligono industrial nº 2 – La Fuensanta

28936 Móstoles - Madrid - (España)

Tel: +34 91 645 00 33

Fax: +34 91 645 69 62

e-mail: [info@koolair.com](mailto:info@koolair.com)

[www.koolair.com](http://www.koolair.com)