

KOOLAIR

series

26

Supply grilles

ISO 9001

BUREAU VERITAS
Certification

Sistema de Gestión



www.koolair.com



INDEX

Curvilinear blade supply air grilles	2
Models	3
Quick selection tables	4
Overview	6
Applications	7
Selection example	8

Curvilinear blade supply air grilles

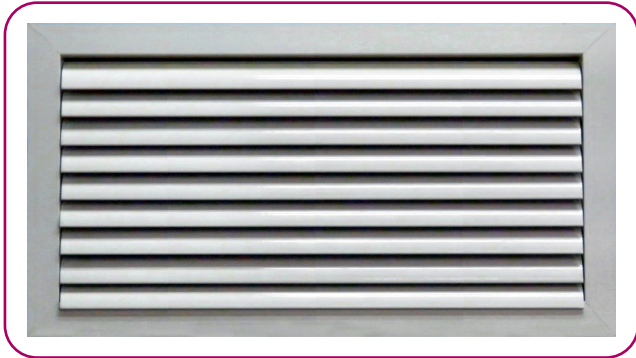

Description

The Series 26 curved blade grilles are especially designed for providing any type of discharge: from the absolute horizontal airstream to the complete vertical airstream, regardless of whether they are ceiling or wall mounted.

The grilles can be used in cooling as well as heating systems, given the great discharge airstream control flexibility of their blades.

The curvilinear blade supply air grille is especially recommended for rooms with a difficult air distribution.

Its curvilinear blades reduce air currents and even ensure air spreading.

They are supplied with 1, 2, 3 and 4 directions.

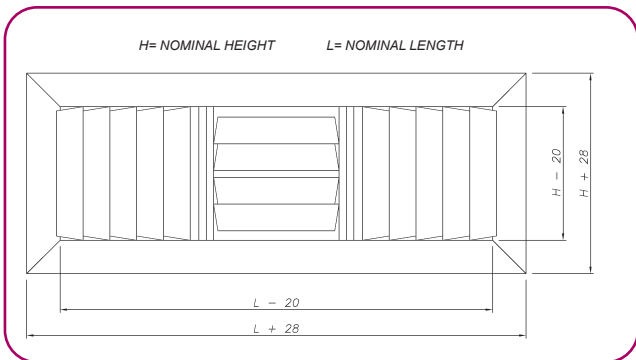

Finishes

Construction: extruded aluminium.

Standard fastening: using zinc-coated screws.

Special: hidden by the mounting frame.

Standard finish: anodized aluminium, non-coated.

Special: other anodized colours or paint finishes area available upon request.

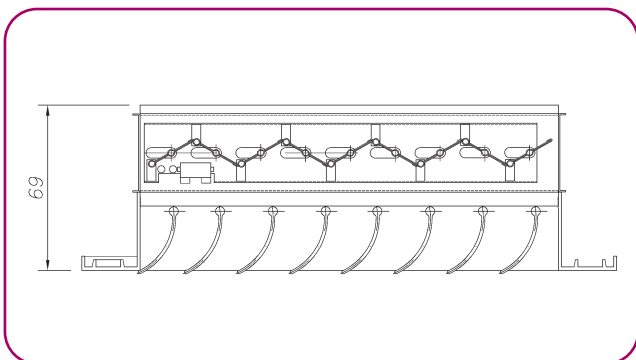

Identification

In all grille dimension descriptions, the first dimension is the length and the second one is the height.

LxH are the mounting opening dimensions.

Curvilinear blade supply air grilles

Models

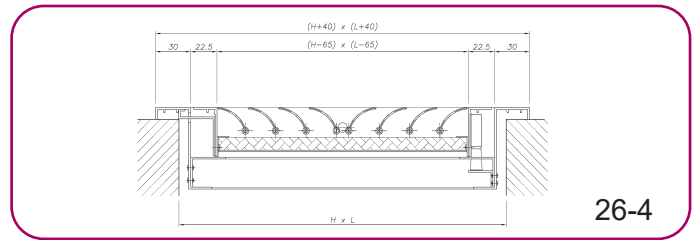
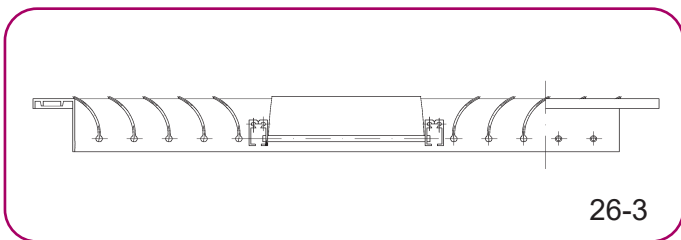
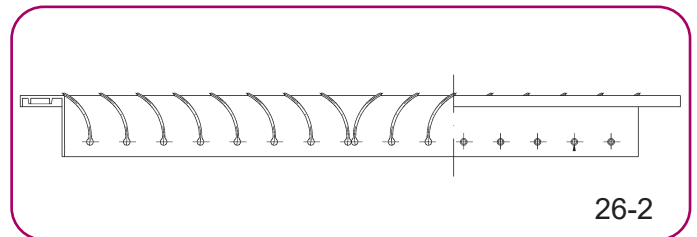
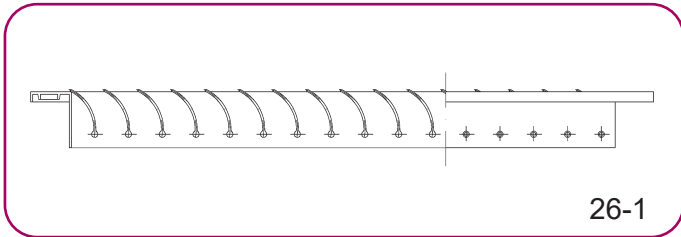

Arrangements

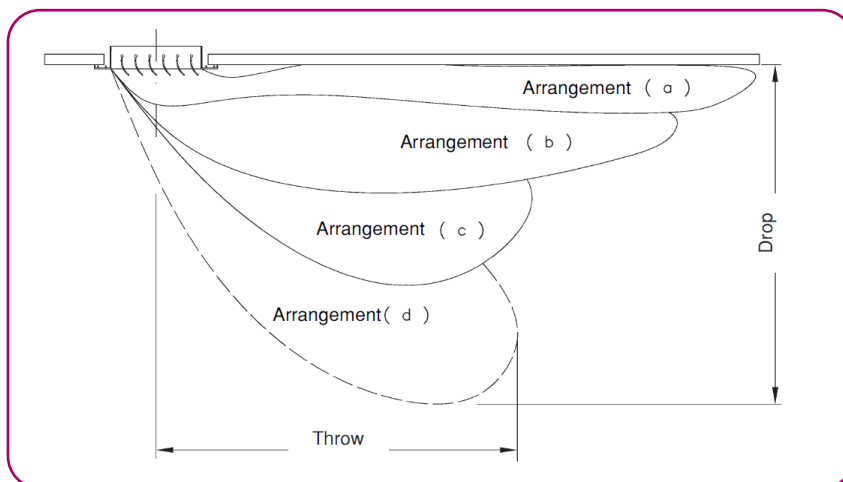
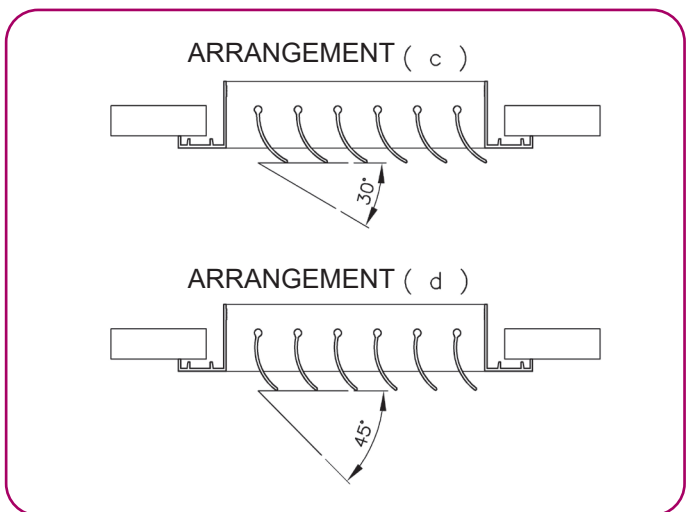
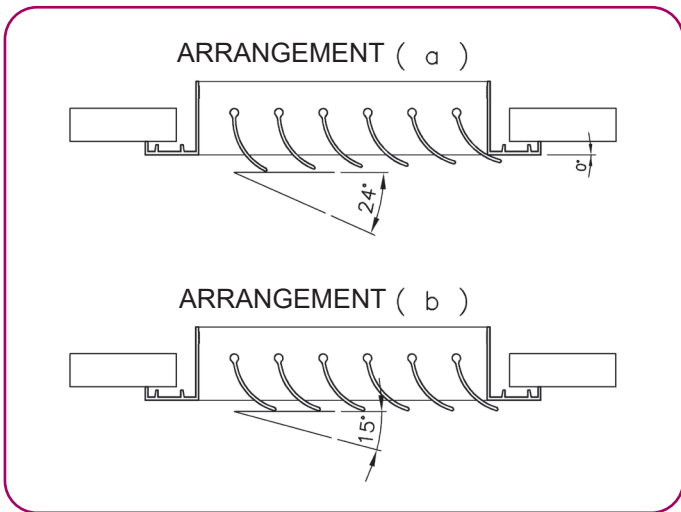

Quick Selection Tables

V	N° of ways	Ps	150 x 150 200 x 125 250 x 100		200 x 200 300 x 150 350 x 125		250 x 250		300 x 300 600 x 150 450 x 200		350 x 350 450 x 250 400 x 300		400 x 400 500 x 300 600 x 250		450 x 450 600 x 300		500 x 500 600 x 450	
			Q	Al	Q	Al	Q	Al	Q	Al	Q	Al	Q	Al	Q	Al	Q	Al
2,5	1 2 3 4	5	75	2,1 1,5 1,5 1	140	2,7 1,8 1,5 1,3	200	3,3 3 1,8 1,5	300	4 2,7 2,4 1,8	400	4,5 3 2,7 2	520	5 3,6 3 2,6	680	5,7 4 3,6 2,7	830	6,3 4,2 4 3
3	1 2 3 4	5	95	2,4 1,5 1,7 1,7	165	3 2 1,8 1,8	245	3,9 2,4 2 2	360	4,5 3 3 2,5	480	5,4 3,6 3,3 2,7	630	6,3 4 3,6 3	815	6,6 4,5 4,2 3,3	1000	7,5 5 4,5 3,6
3,5	1 2 3 4	7,5	110	2,8 1,9 1,5 1,5	190	3,6 2,4 3 3	290	4,5 3 2,7 2,4	420	5 3,6 3,3 2,7	560	6 4,2 4 3	740	7 4,8 4,2 3,3	950	7,8 5,4 4,8 3,9	1160	8,7 6 5 4,2
4	1 2 3 4	10	125	3 2,1 1,7 1,7	215	4,2 2,7 2,5 2,5	335	6 3,3 3 2,7	480	6 4 3,6 3	640	7,3 4,8 4,5 3,3	850	8,1 5,4 4,8 4	1085	9,6 6 5,4 4,5	1320	10,2 6,6 6 4,8
4,5	1 2 3 4	12,5	135	3,3 2,1 1,8 1,8	240	4,5 3 2,9 2,9	375	5,7 3,5 3,5 3	540	7 4,5 4,2 3,3	720	8 5 4,8 4	960	9 5,7 5,4 4,5	1220	10 6,6 6,3 5	1490	11,4 7,2 6,6 5,4
5	1 2 3 4	15	160	3,6 2,5 2,3 1,8	265	5 3,3 3 2,7	420	6,3 4,2 4 3,3	600	7,5 5 4,5 4	800	8,7 5,7 5,4 4,5	1060	10,2 6,6 6,3 5	1355	11,4 7,5 7,2 5,7	1660	12,6 8,6 7,8 6
6	1 2 3 4	22,5	190	4,5 3 2,6 2,5	315	6 4 4,2 3,2	500	7,5 5 4,5 4	720	9 6 5,4 4,5	970	10,5 7 6,3 5	1270	12 8 7,2 6	1630	13,5 9 8 6,6	2000	15 10 8,7 7,2
7	1 2 3 4	30	210	5,4 3,6 3,1 2,9	380	7 4,8 4,2 3,6	580	8,7 6 5,4 4,5	840	10,5 7 6,3 5	1130	12 9 7,5 6	1480	14 9,3 8,4 7	1900	16 10,5 9,7 7,8	2330	17,4 11,9 10,2 8,4
8	1 2 3 4	40	250	6,5 4 3,6 3	430	7,8 5,4 4,5 3,9	660	10 6,6 6 5	960	11,7 7,8 7,2 6	1290	13,8 9,3 8 7	1700	16 10,5 9,6 7,8	2170	18 12 10,8 9	2660	19,8 13,2 11,7 9,6
9	1 2 3 4	50	270	7 4,5 4 3,3	480	8,7 6 5,4 4,5	740	11 7,5 6,6 5,7	1080	13 9 8 6,6	1450	15 10,5 10 7,8	1910	17,4 12,3 10,8 8	2440	20 13,5 12,3 10,2		
10	1 2 3 4	62,5	300	7,5 6 5 3,6	530	10 6,6 6 5	820	12,6 8,4 7,5 6,3	1200	14,7 10 8,7 7,5	1610	17,5 11,4 10,5 8,8	2120	19,8 13,2 11,7 10				

Quick Selection Tables

V	N° of ways	Ps	550 x 550		600 x 600 750 x 500		750 x 750 750 x 500		850 x 850		900 x 900		1050 x 1050		1150 x 1150		1200 x 1200	
			Q	AI	Q	AI	Q	AI	Q	AI	Q	AI	Q	AI	Q	AI	Q	AI
2,5	1	5	1000	7	1225	7,5	1875	9,3	2200	10,2	2700	11,4	3700	13,2	4400	14,7	4800	15,3
	2			4,8		5,4		6,6		7,2		7,8		8		8,7		10,5
	3			4,2		4,5		5,7		6,3		6,6		8		8,7		9,5
	4			3,6		4		4,8		5		5,7		6,6		7,2		7,5
3	1	5	1200	8,4	1475	9,3	2250	11,4	2650	12,3	3250	13,8	4425	15,9	5300	17,4	5800	18,3
	2			5,7		6		7,5		8		9		10,5		11,4		12,3
	3			4,8		5,4		6,6		7,2		7,8		9,3		10		11
	4			4,2		4,5		5,7		6		7		7,8		8,7		9
3,5	1	7,5	1400	9,6	1725	10,5	2625	13,2	3100	14,4	3800	16	5150	18,3	6200	20	6800	21
	2			6,6		7,2		9		9,6		10,8		12,6		13,8		14,4
	3			6		6,6		7,8		8,7		9,3		11		12		12,6
	4			4,8		5		6,3		7		7,8		9		10		10,2
4	1	10	1600	11	1950	12,3	3000	15	3530	16,5	4350	18,3	5875	21,3				
	2			7,5		8		10		10,8		12		14				
	3			6,6		7,2		9		9,6		11		12,6				
	4			5,4		6		7,2		7,8		8,7		10,2				
4,5	1	12,5	1800	12,6	2200	13,8	3375	17,1	4000	18,6	4900	20,7						
	2			8		9		10,8		12		13,2						
	3			7,5		8		10		10,8		12						
	4			6		6,6		8		9		10						
5	1	15	2000	13,8	2450	15,3	3750	19	4450	20,4	5450	22,8						
	2			9		10		12,3		13,5		15						
	3			8,4		9,3		11,4		12,3		13,8						
	4			6,9		7,5		9,3		10,2		11						
6	1	22,5	2400	16,5	2950	18	4525	22,2										
	2			11		12		15										
	3			9,9		10,8		13,5										
	4			8,4		9		11										
7	1	30	2800	19,2	3450	21												
	2			13		14												
	3			12		12,6												
	4			9,6		10,5												
8	1	40																
	2																	
	3																	
	4																	
9	1	50																
	2																	
	3																	
	4																	
10	1	62,5																
	2																	
	3																	
	4																	

Simbolos:
V Discharge velocity m/s
AI Throw in m
P_s Static pressure in Pa
Q Flow m³/h

The throw values indicated in the table are maximum throw values.

Overview

The data listed in the selection tables have been determined using arrangement (a) as a baseline (refer to page 3). For other arrangements, apply the correction factors in Table 1.

All these values correspond to a temperature gradient between the supply and room air of 10° C. During the cooling process, the throw will slightly decrease while the drop will increase. On the contrary, in the heating process, the throws will slightly increase.

Throws

Maximum	Minimum
It is the distance in m (measured in a plane parallel to the grille) from the centre of the grille to a point in which the residual velocity is 0.25 m/sec.	It is the distance in m (measured in a plane parallel to the grille) from the centre of the grille to a point in which the residual velocity is 0.75 m/sec. It is approximately 40 percent of the maximum throw. When the grille is mounted detached from the ceiling, e.g. on a visible duct, the throw is reduced between 15 and 20%, and the drop increases between 5 and 15%..

Drop

It is the distance in m (measured in a plane perpendicular to the grille) from the outlet to a point in which the residual velocity is 0.25 m/sec.

In order to determine the throw, drop and static pressure values for arrangements b, c and d, multiply the throw values in the selection table by the factors listed in Table 1.

Arrangement	Throw	Drop	Static pressure
a	-1	0	1
b	0,7	0,1	0,8
c	0,6	0,2	0,6
d	0,5	0,25	0,5

Applications

Wall applications

In heating operation, it is recommended that the discharge velocity does not exceed 1.5 m/sec.
 In cooling operation, the maximum throws must be equal or greater than the distance from the grille to the ceiling.

Maximum recommended velocities	
Application	Discharge velocity (m/seg)
Radio and TV studios	2,5
Residencies. Apartments. Churches. Hotel rooms	2,5 to 3,5
Theatres. Conference rooms	3 to 5
Private offices. Reading rooms. Classrooms. Museums	5 to 6
Public offices. Upper floors at warehouses	6 to 7
Warehouses (lower floor). Garages. Cafeterias. Supermarkets	7 to 8
Industrial buildings	8 to 10

Ceiling application

Free space	Limited space
<p>The grille is considered to be located in a free space when the maximum throw is reached at a point between 3/4 and the total distance to the nearest wall. The airstream drop in cooling operation will not be excessive if the supply air flow is less than what is indicated in Table 3. When the grille is installed detached from the ceiling, e. g. on a visible duct, the throw is reduced between 15 and 20%, and the drop increases between 5 and 15%.</p>	<p>Includes the grilles located at a distance from the wall that is equal or greater than the minimum throw, which is approximately equal to 40 percent of the maximum throw value listed in the selection table.</p> <p>The maximum throw must not exceed the sum of the distances from the grille to the wall and the ceiling to the floor.</p> <p>When it reaches the front wall, the airstream will spread throughout the surface of the wall, and therefore its throw will decrease.</p> <p>This effect is similar both in cooling as well as in heating operation.</p>

Application in free space and in cooling operation				
Ceiling height (in m)	Maximum flow per grille (m³/h)			
	1 direction	2 directions	3 directions	4 directions
2,5	250	500	750	1000
2,7	400	800	1200	1600
3,0	600	1200	1800	2400
3,2	750	1500	2250	3000
3,5	950	1900	2850	3800
4,0	1200	2400	3600	4800
5,0	1600	3200	4800	6400

Selection example

Free space

Determine the type, number of grilles required, and their dimensions in order to provide air conditioning for an office measuring 48x24 m², with a ceiling height of 2.7 m. The system must supply a total flow of 10,000 m³/h.

Solution:

Divide the total space into 8 areas measuring 12 m x 12 m each, which would require 8 4-way grilles, installed in the centre of each area, with each unit supplying 1,250 m³/h.

Check that the value obtained is smaller than that recommended in Table 3.

Locate in the selection table a grille capable of supplying 1,250 m³/h with a throw of 6 m.

We select a 400 x 400 mm grille with the following characteristics:

Q 1,250 m³/h
Al 6 m
V 6 m/sec
Ps 2.25 mm

The next step is to check that the discharge velocity is within the recommendations provided in the table for a public office and that the selection is correct and the required conditions are met.

Limited space

Determine the dimensions of a grille capable of supplying 500 m³/h for air conditioning a room. The airflow must be directed towards the wall from a grille located on the ceiling, at a height of 3 m.

Solution:

If the grille is installed at 2.5 m from the wall, the maximum throw must not exceed 5.5 m (2.5 m horizontally + 3 m vertically).

The distance of 2.5 m from the wall is greater than the minimum throw (40% of the maximum) and therefore, the position is correct in accordance with the requirements for a limited space.

We locate a 600 x 250 mm, one direction grille in the selection table with the following characteristics:

Q 500 m³/h
Al 5 m
V 2,5 m/sec
Ps 0.5 mm

The next step is to check that the discharge velocity value is within those recommended for this type of application and that the choice is correct.

THIS CATALOGUE IS INTELLECTUAL PROPERTY.

Partial or complete reproduction of its contents is prohibited without the written and certified consent of KOOLAIR, S.L.



KOOLAIR, S.L.

Calle Urano, 26

Poligono industrial nº 2 – La Fuensanta

28936 Móstoles - Madrid - (España)

Tel: +34 91 645 00 33

e-mail: info@koolair.com

www.koolair.com