

KOOLAIR

series

50

Square and rectangular diffusers

ISO 9001

BUREAU VERITAS
Certification

Sistema de Gestión



www.koolair.com



CONTENTS

Square and rectangular diffusers	2
Quick selection tables	3
General information	9
Useful recommendations	10
Accessories and mounting	14
Diffuser and accessory combinations	15
Off-standard rectangular diffusers	16
Stamped square diffusers 52-FR-4 Stamp	17
Dimensions	18
Selection tables	19

Square and rectangular diffusers 50 FR

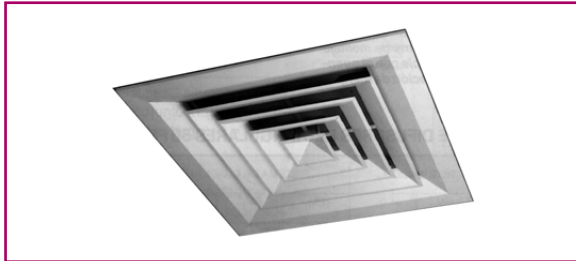

Description

Type 50 FR, square or rectangular aluminium diffuser.

Finishes

Anodised aluminium in its natural colour. Special finishes available upon request.

General dimensions

See page 16 and 17 for sizes. Other dimensions can be found in the drawings in the left column.

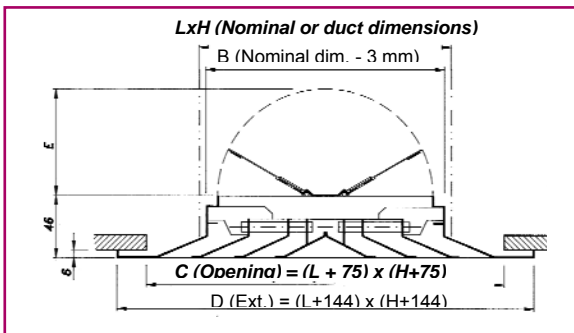
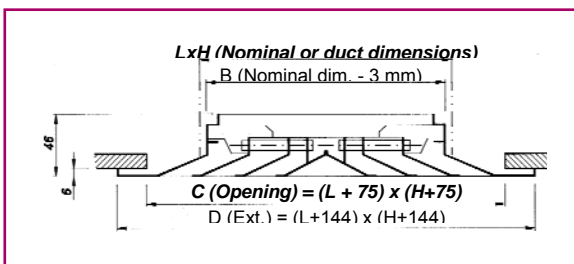

50-FR-4

4 Way square diffuser. Normalised neck according to ISO standard for duct mounting. The free opening should be 75 mm. more than the nominal dimension LxH. E.g. a 300x300 size diffuser would need a free opening in the false ceiling of 375x375 mm.

50-FR-4 + 59 MM

4 Way square diffuser with flap damper.

For duct mounting a mounting bridge can be incorporated for fibre ducts (PM) or sheet ducts (PMC).

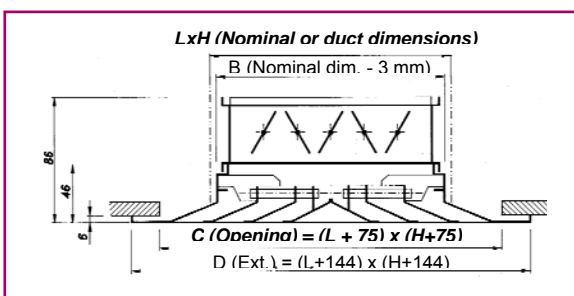

50-FR-4 + 0

4 Way square diffuser with opposed blade damper. Mounting of the diffuser to the duct by means of screws, rivets or adhesive tape. The use of the mounting system (SM) is recommended as an additional support in false ceilings.

50-FR	Series, aluminium diffuser
4, 1, 2, 2-I, 2D, 3	N° of ways of blowing.
-59 MM	Flap damper
O	Opposed blade damper
	Without indication, not incorporated
+ PM	Mounting bridge for fibre ducts
+ PMC	Mounting bridge for sheet ducts
+ SM	Without indication, not incorporated
Size	LxH, from 6 to 24 according to table
Dimensions	LxH, from 150 to 600 according to table

Identification

The central core of the diffuser can easily be removed by means of pressure clips to obtain access to the volume control damper and the duct connection. On page 16 the various combinations of diffusers and accessories (volume control and mounting) are indicated, independent on the number of ways of blowing.

Quick Selection Table (diffusers type 50 FR-4)

Flow rate		mm	150x150	225x225	300x300	375x375	450x450	525x525	600x600
(m ³ /h)	(l/s)	tipo	6x6	9x9	12x12	15x15	18x18	21x21	24x24
		A _k	0,0109	0,0244	0,0435	0,0679	0,0978	0,1331	0,1739
100	27,8	V _k	2,5	1,1					
		X	0,5	0,3					
		p _t	4,5	0,9					
		NR	18						
120	33,3	V _k	3,1	1,4					
		X	0,6	0,4					
		p _t	6,5	1,3					
		NR	22	6					
140	38,9	V _k	3,6	1,6					
		X	0,7	0,5					
		p _t	8,9	1,8					
		NR	26	9					
160	44,4	V _k	4,1	1,8	1,0				
		X	0,8	0,5	0,4				
		p _t	11,6	2,3	0,7				
		NR	29	13					
180	50,0	V _k	4,6	2,0	1,1				
		X	0,9	0,6	0,4				
		p _t	14,7	2,9	0,9				
		NR	32	16					
200	55,6	V _k	5,1	2,3	1,3				
		X	1,0	0,7	0,5				
		p _t	18,2	3,6	1,1				
		NR	35	18	6				
250	69,4	V _k	6,4	2,8	1,6	1,0			
		X	1,2	0,8	0,6	0,5			
		p _t	28,4	5,7	1,8	0,7			
		NR	40	24	12				
300	83,3	V _k	7,6	3,4	1,9	1,2			
		X	1,5	1,0	0,7	0,6			
		p _t	40,9	8,2	2,6	1,1			
		NR	45	28	16	7			
350	97,2	V _k	8,9	4,0	2,2	1,4	1,0		
		X	1,7	1,2	0,9	0,7	0,6		
		p _t	55,7	11,1	3,5	1,4	0,7		
		NR	49	32	20	11			
400	111,1	V _k		4,6	2,6	1,6	1,1		
		X		1,3	1,0	0,8	0,7		
		p _t		14,5	4,6	1,9	0,9		
		NR		35	24	15	7		
450	125,0	V _k		5,1	2,9	1,8	1,3		
		X		1,5	1,1	0,9	0,7		
		p _t		18,4	5,8	2,4	1,1		
		NR		38	27	17	10		
500	138,9	V _k		5,7	3,2	2,0	1,4		
		X		1,7	1,2	1,0	0,8		
		p _t		22,7	7,1	2,9	1,4		
		NR		41	29	20	13		
600	166,7	V _k		6,8	3,8	2,5	1,7	1,3	
		X		2,0	1,5	1,2	1,0	0,9	
		p _t		32,7	10,3	4,2	2,0	1,1	
		NR		45	34	25	17	11	

Flow rate		mm	150x150	225x225	300x300	375x375	450x450	525x525	600x600
(m ³ /h)	(l/s)	tipo	6x6	9x9	12x12	15x15	18x18	21x21	24x24
		A _k	0,0109	0,0244	0,0435	0,0679	0,0978	0,1331	0,1739
700	194,4	V _k		8,0	4,5	2,9	2,0	1,5	1,1
		X		2,3	1,7	1,4	1,2	1,0	0,9
		p _t		44,5	14,0	5,7	2,8	1,5	0,9
		NR		49	37	28	21	15	9
800	222,2	V _k			5,1	3,3	2,3	1,7	1,3
		X			2,0	1,6	1,3	1,1	1,0
		p _t			18,3	7,5	3,6	2,0	1,1
		NR			41	32	24	18	12
900	250,0	V _k			5,7	3,7	2,6	1,9	1,4
		X			2,2	1,8	1,5	1,3	1,1
		p _t			23,1	9,5	4,6	2,5	1,4
		NR			44	35	27	21	15
1000	277,8	V _k			6,4	4,1	2,8	2,1	1,6
		X			2,5	2,0	1,7	1,4	1,2
		p _t			28,5	11,7	5,6	3,0	1,8
		NR			46	37	30	23	18
1200	333,3	V _k			7,7	4,9	3,4	2,5	1,9
		X			3,0	2,4	2,0	1,7	1,5
		p _t			41,1	16,9	8,1	4,4	2,6
		NR			51	42	34	28	23
1400	388,9	V _k				5,7	4,0	2,9	2,2
		X				2,8	2,3	2,0	1,7
		p _t				23,0	11,1	6,0	3,5
		NR				46	38	32	26
1600	444,4	V _k				6,5	4,5	3,3	2,6
		X				3,2	2,7	2,3	2,0
		p _t				30,0	14,5	7,8	4,6
		NR				49	41	35	30
1800	500,0	V _k				7,4	5,1	3,8	2,9
		X				3,6	3,0	2,6	2,2
		p _t				38,0	18,3	9,9	5,8
		NR				52	44	38	33
2000	555,6	V _k					5,7	4,2	3,2
		X					3,3	2,9	2,5
		p _t					22,6	12,2	7,1
		NR					47	41	35
2500	694,4	V _k					7,1	5,2	4,0
		X					4,2	3,6	3,1
		p _t					35,3	19,1	11,2
		NR					52	46	41
3000	833,3	V _k						6,3	4,8
		X						4,3	3,7
		p _t						27,4	16,1
		NR						51	45
3500	972,2	V _k						7,3	5,6
		X						5,0	4,4
		p _t						37,3	21,9
		NR						54	49
4000	1111,1	V _k						8,3	6,4
		X						5,7	5,0
		p _t						48,8	28,6
		NR						58	52

Symbols:

- V_k = Effective velocity in m/s
- X = Throw in m
- P_t = Total pressure in Pa
- NR = Noise level index in dB

The selection should take into account, for a given air flow rate, the noise level and the throw. The throws given in the table correspond to a maximum velocity in the occupied zone of 0,25 m/s.



50-FR-1
Square diffuser with central core in one way.



50-FR-2
Square diffuser with central core in two ways.

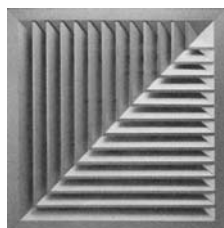

50-FR-2D
Square diffuser with central core in two ways 90°.



50-FR-2-L
Rectangular diffuser with central core in two ways.



50-FR-3
Square diffuser with central core in three ways.

Quick Selection Table (diffusers type 50 FR-1)

Flow rate		mm	150x150	225x225	300x300	375x375	450x450	525x525	600x600
		tipo	6x6	9x9	12x12	15x15	18x18	21x21	24x24
(m³/h)	(l/s)	A _k	0,0096	0,0215	0,0383	0,0598	0,0863	0,1174	0,1534
50	13,9	V _k	1,4						
		X	0,9						
		p _t	1,5						
		NR							
60	16,7	V _k	1,7						
		X	1,1						
		p _t	2,1						
		NR	9						
70	19,4	V _k	2,0	0,9					
		X	1,2	0,8					
		p _t	2,9	0,6					
		NR	13						
80	22,2	V _k	2,3	1,0					
		X	1,4	0,9					
		p _t	3,8	0,7					
		NR	16						
90	25,0	V _k	2,6	1,2					
		X	1,6	1,1					
		p _t	4,7	0,9					
		NR	19						
100	27,8	V _k	2,9	1,3					
		X	1,8	1,2					
		p _t	5,9	1,2					
		NR	22	5					
120	33,3	V _k	3,5	1,6	0,9				
		X	2,1	1,4	1,1				
		p _t	8,4	1,7	0,5				
		NR	26	9					
140	38,9	V _k	4,1	1,8	1,0				
		X	2,5	1,6	1,2				
		p _t	11,5	2,3	0,7				
		NR	30	13					
160	44,4	V _k	4,6	2,1	1,2				
		X	2,8	1,9	1,4				
		p _t	15,0	3,0	0,9				
		NR	33	16					
180	50,0	V _k	5,2	2,3	1,3				
		X	3,2	2,1	1,6				
		p _t	19,0	3,8	1,2				
		NR	36	19	7				
200	55,6	V _k	5,8	2,6	1,5	0,9			
		X	3,5	2,3	1,8	1,4			
		p _t	23,4	4,7	1,5	0,6			
		NR	39	22	10				
250	69,4	V _k	7,2	3,2	1,8	1,2	0,8		
		X	4,4	2,9	2,2	1,8	1,5		
		p _t	36,6	7,3	2,3	0,9	0,5		
		NR	44	28	15	6			
300	83,3	V _k		3,9	2,2	1,4	1,0		
		X		3,5	2,6	2,1	1,8		
		p _t		10,5	3,3	1,4	0,7		
		NR		32	20	11			

Flow rate		mm	150x150	225x225	300x300	375x375	450x450	525x525	600x600
		tipo	6x6	9x9	12x12	15x15	18x18	21x21	24x24
(m³/h)	(l/s)	A _k	0,0096	0,0215	0,0383	0,0598	0,0863	0,1174	0,1534
350	97,2	V _k		4,5	2,5	1,6	1,1	0,8	
		X		4,1	3,1	2,5	2,0	1,8	
		p _t		14,3	4,5	1,9	0,9	0,5	
		NR		36	24	15	7		
400	111,1	V _k		5,2	2,9	1,9	1,3	0,9	
		X		4,7	3,5	2,8	2,3	2,0	
		p _t		18,7	5,9	2,4	1,2	0,6	
		NR		39	27	18	10		
500	138,9	V _k		6,5	3,6	2,3	1,6	1,2	0,9
		X		5,8	4,4	3,5	2,9	2,5	2,2
		p _t		29,2	9,2	3,8	1,8	1,0	0,6
		NR		45	33	23	16	9	
600	166,7	V _k			4,4	2,8	1,9	1,4	1,1
		X			5,3	4,2	3,5	3,0	2,6
		p _t			13,3	5,4	2,6	1,4	0,8
		NR			37	28	20	14	8
700	194,4	V _k			5,1	3,3	2,3	1,7	1,3
		X			6,1	4,9	4,1	3,5	3,1
		p _t			18,0	7,4	3,6	1,9	1,1
		NR			41	32	24	18	12
800	222,2	V _k			5,8	3,7	2,6	1,9	1,4
		X			7,0	5,6	4,7	4,0	3,5
		p _t			23,6	9,7	4,6	2,5	1,5
		NR			44	35	27	21	15
900	250,0	V _k			6,5	4,2	2,9	2,1	1,6
		X			7,9	6,3	5,3	4,5	3,9
		p _t			29,8	12,2	5,9	3,2	1,9
		NR			47	38	30	24	18
1000	277,8	V _k				4,6	3,2	2,4	1,8
		X				7,0	5,8	5,0	4,4
		p _t				15,1	7,3	3,9	2,3
		NR				41	33	26	21
1200	333,3	V _k				5,6	3,9	2,8	2,2
		X				8,4	7,0	6,0	5,3
		p _t				21,7	10,4	5,6	3,3
		NR				45	37	31	25
1400	388,9	V _k				6,5	4,5	3,3	2,5
		X				9,8	8,2	7,0	6,1
		p _t				29,6	14,2	7,7	4,5
		NR				49	41	35	29
1600	444,4	V _k					5,1	3,8	2,9
		X					9,3	8,0	7,0
		p _t					18,6	10,0	5,9
		NR					44	38	33
1800	500,0	V _k					5,8	4,3	3,3
		X					10,5	9,0	7,9
		p _t					23,5	12,7	7,4
		NR					47	41	35
2000	555,6	V _k					6,4	4,7	3,6
		X					11,7	10,0	8,8
		p _t					29,0	15,7	9,2
		NR					50	44	38

Symbols:

- V_k = Effective velocity in m/s
- X = Throw in m
- P_t = Total pressure in Pa
- NR = Noise level index in dB

The selection should take into account, for a given air flow rate, the noise level and the throw. The throws given in the table correspond to a maximum velocity in the occupied zone of 0,25 m/s.

Quick Selection Table (diffusers type 50 FR-2)

Flow rate		mm	150x150	225x225	300x300	375x375	450x450	525x525	600x600
(m³/h)	(l/s)	tipo	6x6	9x9	12x12	15x15	18x18	21x21	24x24
100	27,8	V _k X p _t NR	0,0093 3,0 0,6 6,7 22	0,0209 1,3 0,4 1,3 5	0,0373	0,0582	0,0838	0,1141	0,1490
120	33,3	V _k X p _t NR	3,6 0,7 9,6 26	1,6 0,5 1,9 10					
140	38,9	V _k X p _t NR	4,2 0,9 13,1 30	1,9 0,6 2,6 14	1,0 0,4 0,8				
160	44,4	V _k X p _t NR	4,8 1,0 17,1 33	2,1 0,7 3,4 17	1,2 0,5 1,1 5				
180	50,0	V _k X p _t NR	5,4 1,1 21,7 36	2,4 0,7 4,3 20	1,3 0,5 1,3 8				
200	55,6	V _k X p _t NR	6,0 1,2 26,8 39	2,7 0,8 5,3 22	1,5 0,6 1,7 11	1,0 0,5 0,7			
250	69,4	V _k X p _t NR	7,5 1,5 41,8 44	3,3 1,0 8,3 28	1,9 0,8 2,6 16	1,2 0,6 1,1 7			
300	83,3	V _k X p _t NR		4,0 1,2 11,9 32	2,2 0,9 3,7 21	1,4 0,7 1,5 12	1,0 0,6 0,7		
350	97,2	V _k X p _t NR		4,7 1,4 16,2 36	2,6 1,1 5,1 24	1,7 0,9 2,1 15	1,2 0,7 1,0 8		
400	111,1	V _k X p _t NR		5,3 1,6 21,2 40	3,0 1,2 6,7 28	1,9 1,0 2,7 19	1,3 0,8 1,3 11	1,0 0,7 0,7 5	
450	125,0	V _k X p _t NR		6,0 1,8 26,8 42	3,4 1,4 8,4 31	2,1 1,1 3,5 22	1,5 0,9 1,7 14	1,1 0,8 0,9 8	
500	138,9	V _k X p _t NR		6,6 2,0 33,1 45	3,7 1,5 10,4 33	2,4 1,2 4,3 24	1,7 1,0 2,1 17	1,2 0,9 1,1 10	0,9 0,8 0,7 5
600	166,7	V _k X p _t NR			4,5 1,8 15,0 38	2,9 1,5 6,2 29	2,0 1,2 3,0 21	1,5 1,0 1,6 15	1,1 0,9 0,9 10

Flow rate		mm	150x150	225x225	300x300	375x375	450x450	525x525	600x600
(m³/h)	(l/s)	tipo	6x6	9x9	12x12	15x15	18x18	21x21	24x24
700	194,4	V _k X p _t NR			5,2 2,1 20,4 42	3,3 1,7 8,4 33	2,3 1,4 4,0 25	1,7 1,2 2,2 19	1,3 1,1 1,3 13
800	222,2	V _k X p _t NR			6,0 2,4 26,6 45	3,8 1,9 10,9 36	2,7 1,6 5,3 28	1,9 1,4 2,8 22	1,5 1,2 1,7 17
900	250,0	V _k X p _t NR			6,7 2,7 33,7 48	4,3 2,2 13,8 39	3,0 1,8 6,7 31	2,2 1,6 3,6 25	1,7 1,4 2,1 20
1000	277,8	V _k X p _t NR			7,4 3,0 41,6 50	4,8 2,4 17,1 41	3,3 2,0 8,2 34	2,4 1,7 4,4 28	1,9 1,5 2,6 22
1200	333,3	V _k X p _t NR				5,7 2,9 24,6 46	4,0 2,4 11,9 38	2,9 2,1 6,4 32	2,2 1,8 3,8 27
1400	388,9	V _k X p _t NR				6,7 3,4 33,5 50	4,6 2,8 16,2 42	3,4 2,4 8,7 36	2,6 2,1 5,1 30
1600	444,4	V _k X p _t NR					5,3 3,2 21,1 46	3,9 2,8 11,4 39	3,0 2,4 6,7 34
1800	500,0	V _k X p _t NR					6,0 3,7 26,7 48	4,4 3,1 14,4 42	3,4 2,7 8,4 37
2000	555,6	V _k X p _t NR					6,6 4,1 33,0 51	4,9 3,5 17,8 45	3,7 3,0 10,4 39
2500	694,4	V _k X p _t NR						6,1 4,4 27,8 50	4,7 3,8 16,3 45
3000	833,3	V _k X p _t NR						7,3 5,2 40,0 55	5,6 4,6 23,5 49
3500	972,2	V _k X p _t NR							6,5 5,3 31,9 53
4000	1111,1	V _k X p _t NR							7,5 6,1 41,7 56

Symbols:

- V_k = Effective velocity in m/s
- X = Throw in m
- p_t = Total pressure in Pa
- NR = Noise level index in dB

The selection should take into account, for a given air flow rate, the noise level and the throw. The throws given in the table correspond to a maximum velocity in the occupied zone of 0,25 m/s.

Quick Selection Table (diffusers type 50 FR-2D)

Flow rate		Dim.(mm)	150x150	225x225	300x300	375x375	450x450	525x525	600x600
Q		tipo	6x6	9x9	12x12	15x15	18x18	21x21	24x24
(m³/h)	(l/s)	A _k (m²)	0,0098	0,0219	0,0391	0,0610	0,0881	0,1198	0,1565
100	27,8	V _k (m/s) X (m) p _t (Pa) NR	2,8 0,9 5,6 21	1,3 0,6 1,1 4					
120	33,3	V _k (m/s) X (m) p _t (Pa) NR	3,4 1,1 8,1 26	1,5 0,7 1,6 9					
140	38,9	V _k (m/s) X (m) p _t (Pa) NR	4,0 1,3 11,0 30	1,8 0,8 2,2 13					
160	44,4	V _k (m/s) X (m) p _t (Pa) NR	4,5 1,4 14,4 33	2,0 1,0 2,9 16	1,1 0,7 0,9 4				
180	50,0	V _k (m/s) X (m) p _t (Pa) NR	5,1 1,6 18,2 36	2,3 1,1 3,6 19	1,3 0,8 1,1 7				
200	55,6	V _k (m/s) X (m) p _t (Pa) NR	5,7 1,8 22,5 38	2,5 1,2 4,5 22	1,4 0,9 1,4 10				
250	69,4	V _k (m/s) X (m) p _t (Pa) NR	7,1 2,2 35,1 44	3,2 1,5 7,0 27	1,8 1,1 2,2 15				
300	83,3	V _k (m/s) X (m) p _t (Pa) NR	8,5 2,7 50,6 48	3,8 1,8 10,1 32	2,1 1,3 3,2 20	1,4 0,9 1,3 10	0,9 0,6 3		
350	97,2	V _k (m/s) X (m) p _t (Pa) NR	9,9 3,1 68,9 52	4,4 2,1 13,8 35	2,5 1,6 4,3 23	1,6 1,3 1,8 14	1,1 1,0 0,9 6		
400	111,1	V _k (m/s) X (m) p _t (Pa) NR		5,1 2,4 18,0 39	2,8 1,8 5,7 27	1,8 1,4 2,3 17	1,3 1,2 1,1 10	0,9 1,0 0,6 3	
450	125,0	V _k (m/s) X (m) p _t (Pa) NR		5,7 2,7 22,8 42	3,2 2,0 7,2 30	2,0 1,6 2,9 20	1,4 1,3 1,4 13	1,0 1,2 0,8 6	
500	138,9	V _k (m/s) X (m) p _t (Pa) NR		6,3 3,0 28,2 44	3,6 2,2 8,8 32	2,3 1,8 3,6 23	1,6 1,5 1,7 15	1,2 1,3 0,9 9	0,9 1,1 0,6 3
600	166,7	V _k (m/s) X (m) p _t (Pa) NR		7,6 3,6 40,5 49	4,3 2,7 12,7 37	2,7 2,2 5,2 27	1,9 1,8 2,5 20	1,4 1,5 1,4 13	1,1 1,3 0,8 8

Flow rate		Dim.(mm)	150x150	225x225	300x300	375x375	450x450	525x525	600x600
Q		tipo	6x6	9x9	12x12	15x15	18x18	21x21	24x24
(m³/h)	(l/s)	A _k (m²)	0,0098	0,0219	0,0391	0,0610	0,0881	0,1198	0,1565
700	194,4	V _k (m/s) X (m) p _t (Pa) NR		8,9 4,2 55,2 53	5,0 3,1 17,3 41	3,2 2,5 7,1 31	2,2 2,1 3,4 24	1,6 1,8 1,8 17	1,2 1,6 1,1 12
800	222,2	V _k (m/s) X (m) p _t (Pa) NR			5,7 3,6 22,6 44	3,6 2,9 9,3 35	2,5 2,4 4,5 27	1,9 2,1 2,4 21	1,4 1,8 1,4 15
900	250,0	V _k (m/s) X (m) p _t (Pa) NR			6,4 4,0 28,6 47	4,1 3,2 11,8 37	2,8 2,7 5,6 30	2,1 2,3 3,0 23	1,6 2,0 1,8 18
1000	277,8	V _k (m/s) X (m) p _t (Pa) NR			7,1 4,5 35,3 49	4,6 3,6 14,5 40	3,2 3,0 7,0 32	2,3 2,6 3,8 26	1,8 2,2 2,2 20
1200	333,3	V _k (m/s) X (m) p _t (Pa) NR			8,5 5,4 50,9 54	5,5 4,3 20,9 45	3,8 3,6 10,0 37	2,8 3,1 5,4 31	2,1 2,7 3,2 25
1400	388,9	V _k (m/s) X (m) p _t (Pa) NR				6,4 5,0 28,5 48	4,4 4,2 13,6 41	3,2 3,6 7,4 34	2,5 3,1 4,3 29
1600	444,4	V _k (m/s) X (m) p _t (Pa) NR				7,3 5,8 37,2 52	5,0 4,8 17,8 44	3,7 4,1 9,6 38	2,8 3,6 5,6 32
1800	500,0	V _k (m/s) X (m) p _t (Pa) NR				8,2 6,5 47,0 55	5,7 5,4 22,5 47	4,2 4,6 12,2 41	3,2 4,0 7,1 35
2000	555,6	V _k (m/s) X (m) p _t (Pa) NR					6,3 6,0 27,8 50	4,6 5,1 15,1 43	3,5 4,5 8,8 38
2500	694,4	V _k (m/s) X (m) p _t (Pa) NR					7,9 7,5 43,5 55	5,8 6,4 23,5 49	4,4 5,6 13,8 43
3000	833,3	V _k (m/s) X (m) p _t (Pa) NR						7,0 7,7 33,9 53	5,3 6,7 19,8 48
3500	972,2	V _k (m/s) X (m) p _t (Pa) NR							6,2 7,9 27,0 51
4000	#####	V _k (m/s) X (m) p _t (Pa) NR							7,1 9,0 35,3 55

Symbols:

- V_k = Effective velocity in m/s
- X = Throw in m
- P_t = Total pressure in Pa
- NR = Noise level index in dB

The selection should take into account, for a given air flow rate, the noise level and the throw. The throws given in the table correspond to a maximum velocity in the occupied zone of 0,25 m/s.

Quick Selection Table (diffusers type 50 FR-2-L)

Flow rate		mm	225x150	300x150	300x225	375x225	450x225
(m ³ /h)	(l/s)	tipo	9x6	12x6	12x9	15x9	18x9
100	27,8	V _k	2,0	1,5			
		X	0,5	0,4			
		p _t	3,0	1,7			
		NR	13	8			
120	33,3	V _k	2,4	1,8			
		X	0,6	0,5			
		p _t	4,3	2,4			
		NR	18	12			
140	38,9	V _k	2,8	2,1			
		X	0,7	0,6			
		p _t	5,8	3,3			
		NR	22	16			
160	44,4	V _k	3,2	2,4	1,6		
		X	0,8	0,7	0,6		
		p _t	7,6	4,3	1,9		
		NR	25	19	11		
180	50,0	V _k	3,6	2,7	1,8		
		X	0,9	0,8	0,6		
		p _t	9,6	5,4	2,4		
		NR	28	22	14		
200	55,6	V _k	4,0	3,0	2,0	1,6	
		X	1,0	0,9	0,7	0,6	
		p _t	11,8	6,7	3,0	1,9	
		NR	31	25	17	12	
225	62,5	V _k	4,5	3,4	2,2	1,8	
		X	1,1	1,0	0,8	0,7	
		p _t	14,9	8,5	3,8	2,4	
		NR	33	28	19	15	
250	69,4	V _k	5,0	3,7	2,5	2,0	1,7
		X	1,2	1,1	0,9	0,8	0,7
		p _t	18,5	10,5	4,6	3,0	2,1
		NR	36	30	22	18	14
300	83,3	V _k	6,0	4,5	3,0	2,4	2,0
		X	1,5	1,3	1,1	0,9	0,9
		p _t	26,6	15,1	6,7	4,3	3,0
		NR	41	35	27	22	18
350	97,2	V _k	6,9	5,2	3,5	2,8	2,3
		X	1,7	1,5	1,2	1,1	1,0
		p _t	36,2	20,5	9,1	5,9	4,1
		NR	44	39	30	26	22
400	111,1	V _k	7,9	6,0	4,0	3,2	2,7
		X	2,0	1,7	1,4	1,3	1,1
		p _t	47,2	26,8	11,9	7,6	5,3
		NR	48	42	34	29	25
450	125,0	V _k		6,7	4,5	3,6	3,0
		X		1,9	1,6	1,4	1,3
		p _t		33,9	15,1	9,7	6,7
		NR		45	37	32	28
500	138,9	V _k		7,5	5,0	4,0	3,3
		X		2,2	1,8	1,6	1,4
		p _t		41,8	18,6	11,9	8,3
		NR		47	39	35	31
600	166,7	V _k			6,0	4,8	4,0
		X			2,1	1,9	1,7
		p _t			26,8	17,2	11,9
		NR			44	39	35
700	194,4	V _k			7,0	5,6	4,7
		X			2,5	2,2	2,0
		p _t			36,4	23,4	16,2
		NR			48	43	39
800	222,2	V _k				6,4	5,3
		X				2,5	2,3
		p _t				30,6	21,2
		NR				46	43
900	250,0	V _k				7,2	6,0
		X				2,8	2,6
		p _t				38,7	26,8
		NR				49	45

Symbols:

- V_k = Effective velocity in m/s
- X = Throw in m
- P_t = Total pressure in Pa
- NR = Noise level index in dB

The selection should take into account, for a given air flow rate, the noise level and the throw. The throws given in the table correspond to a maximum velocity in the occupied zone of 0,25 m/s.

Quick Selection Table (diffusers type 50 FR-3)

Flow rate		mm	150x150	225x225	300x300	375x375	450x450
		tipo	6x6	9x9	12x12	15x15	18x18
(m³/h)	(l/s)	A _k (m²)	0,0089	0,0200	0,0355	0,0554	0,0798
100	27,8	V _k	3,1				
		X	0,6				
		P _t	8,5				
		NR	17				
120	33,3	V _k	3,7				
		X	0,7				
		P _t	12,2				
		NR	22				
140	38,9	V _k	4,4	1,9			
		X	0,8	0,6			
		P _t	16,6	3,3			
		NR	25	9			
160	44,4	V _k	5,0	2,2			
		X	1,0	0,6			
		P _t	21,7	4,3			
		NR	29	12			
180	50,0	V _k	5,6	2,5			
		X	1,1	0,7			
		P _t	27,5	5,4			
		NR	32	15			
200	55,6	V _k	6,2	2,8	1,6		
		X	1,2	0,8	0,6		
		P _t	33,9	6,7	2,1		
		NR	34	18	6		
250	69,4	V _k	7,8	3,5	2,0		
		X	1,5	1,0	0,8		
		P _t	53,0	10,5	3,3		
		NR	40	23	12		
300	83,3	V _k	9,4	4,2	2,3	1,5	
		X	1,8	1,2	0,9	0,7	
		P _t	76,3	15,1	4,8	2,0	
		NR	44	28	16	7	
350	97,2	V _k		4,9	2,7	1,8	
		X		1,4	1,1	0,8	
		P _t		20,6	6,5	2,7	
		NR		32	20	11	
400	111,1	V _k		5,6	3,1	2,0	
		X		1,6	1,2	1,0	
		P _t		26,9	8,5	3,5	
		NR		35	23	14	
450	125,0	V _k		6,3	3,5	2,3	1,6
		X		1,8	1,4	1,1	0,9
		P _t		34,0	10,8	4,4	2,1
		NR		38	26	17	10
500	138,9	V _k		6,9	3,9	2,5	1,7
		X		2,0	1,5	1,2	1,0
		P _t		42,0	13,3	5,5	2,6
		NR		40	29	20	12

Flow rate		mm	150x150	225x225	300x300	375x375	450x450
		tipo	6x6	9x9	12x12	15x15	18x18
(m³/h)	(l/s)	A _k (m²)	0,0089	0,0200	0,0355	0,0554	0,0798
600	166,7	V _k			4,7	3,0	2,1
		X			1,8	1,4	1,2
		P _t			19,2	7,9	3,8
		NR			33	24	17
700	194,4	V _k			5,5	3,5	2,4
		X			2,1	1,7	1,4
		P _t			26,1	10,7	5,2
		NR			37	28	21
800	222,2	V _k			6,3	4,0	2,8
		X			2,4	1,9	1,6
		P _t			34,1	14,0	6,7
		NR			40	31	24
900	250,0	V _k			7,0	4,5	3,1
		X			2,7	2,2	1,8
		P _t			43,1	17,7	8,5
		NR			43	34	27
1000	277,8	V _k			7,8	5,0	3,5
		X			3,0	2,4	2,0
		P _t			53,3	21,9	10,5
		NR			46	37	29
1200	333,3	V _k				6,0	4,2
		X				2,9	2,4
		P _t				31,5	15,2
		NR				41	34
1400	388,9	V _k				7,0	4,9
		X				3,4	2,8
		P _t				42,9	20,7
		NR				45	38
1600	444,4	V _k				8,0	5,6
		X				3,9	3,2
		P _t				56,0	27,0
		NR				48	41
1800	500,0	V _k					6,3
		X					3,6
		P _t					34,2
		NR					44
2000	555,6	V _k					7,0
		X					4,0
		P _t					42,2
		NR					47
2500	694,4	V _k					8,7
		X					5,0
		P _t					65,9
		NR					52
3000	833,3	V _k					10,4
		X					6,0
		P _t					94,9
		NR					57

Symbols:

- V_k = Effective velocity in m/s
- X = Throw in m
- P_t = Total pressure in Pa
- NR = Noise level index in dB

The selection should take into account, for a given air flow rate, the noise level and the throw. The throws given in the table correspond to a maximum velocity in the occupied zone of 0,25 m/s.

General information

- The special design of the range of square and rectangular diffusers provides to any kind of space the requirements of decoration which today's architecture demands.

- The broad range of products and possibilities to orientate the air flow in 1, 2, 3 or 4 ways, make them particularly indicated for spaces where a particular zone has to be treated, in geometrically irregular spaces or off-centre parts of the space (conjunction of wall and ceiling, etc.).

- By means of laboratory tests it has been demonstrated that these diffusers are ideal for variable volume systems, due to its blade design, with which an adherent jet is obtained (Coanda effect) with a highly satisfactory efficiency, specially recommendable in cold air installations.

- The volume control damper of the flap type (59MM) is manually adjustable, while the opposed blade type (O) can be adjusted by means of a plane screwdriver.

- All square and rectangular diffuser types have standardised neck dimensions for duct mounting according to ISO standard.

General notes on the quick selection tables :

- These selection tables are based on full-scale laboratory tests according to standards ISO 5219 and ISO 5135 and 3741.

- The jet is adherent, i.e. the diffuser is mounted aligned with the ceiling.

- Room height is $3 \pm 0,5$ m.

- The ΔT is equal to 10 oC, the temperature difference between the room and the supply air.

- Sound index NR is based on sound power, without room attenuation and without damper (mounting according to ISO).

- For the diffuser type 50 FR-2-L the indicated pressure is the total pressure in the duct, before the plenum, while the sound index NR is based on sound power, without room attenuation and without damper, but with plenum (mounting according to ISO for false ceilings).

- Throws given correspond to a maximum velocity (V_z) of 0,25 m/s in the occupied zone.

- For types 50 FR-4, 50 FR-2 and 50 FR-2-L, the diffuser is placed in the centre of a square room.

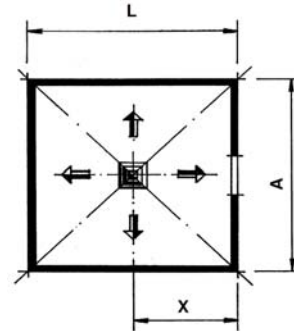

- For type 50 FR-1 the diffuser is placed in the longitudinal axis of the ceiling, close to the wall, with room dimensions L =length and A =width and with a ratio $A/L=0,67$.

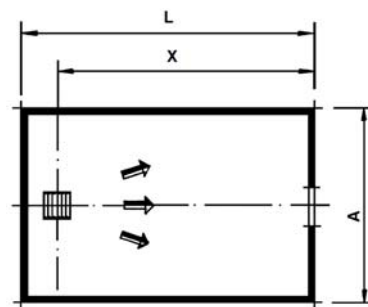

- For type 50 FR-3 the diffuser is placed in the longitudinal axis of the ceiling of a square room ($A/L=1$), at a distance of $L/4$ to the wall.

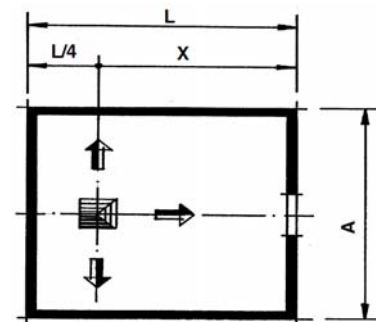

- To obtain the pressure loss or sound level of the square and rectangular diffusers with damper (59MM or O), see the corresponding graphs on page 14.

Example

Requirements:

Air flow rate _____ 400 m³/h
 Throw _____ 1 to 1,5 m
 Sound level _____ below 30 dB
 Application _____ Private offices
 Required pressure loss _____ below 10 Pa
 Exit velocity _____ Maximum 3m/s
 N° of directions _____ 4

Solution:

With the selection table for diffusers type 50 FR-4 and following the general criterion that for comfort installations the recommended discharge velocity for this type of diffusers lies between 2 and 3,5 m/s, we obtain:

Q (Air flow rate) _____ 400 m³/h (166,7 l/s)
 X (Throw) _____ 1,3 m
 NR (Sound level) _____ 24 dB
 P_t (Pressure loss) _____ 4,6 Pa
 V_k (Effective velocity) _____ 2,6 m/s

Diffuser 50 FR-4 size 12x12 (300x300 mm) (with optional delivery of volume control damper and mounting accessories).

Observing the results, the data obtained fulfil the requirements of the project.

Throw correction factor for room width/length ratio.

This factor, called Ca, is given by the ratio of room width and length and is applicable to diffusers type 50 FR-1, 50 FR-2-L and 50 FR-3. For types 50 FR-4 and 50 FR-2 the value of Ca equals 1, since they have been tested in a square room (A/L=1).

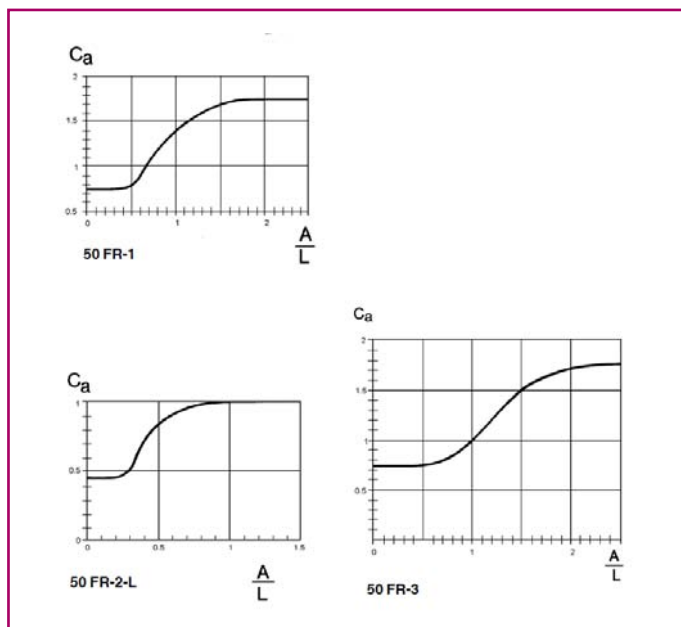

Throw correction factor for distance of diffuser to ceiling (C_h)

For adherent jets, i.e. diffuser aligned with ceiling: $C_h=1$
 For free jets, with the diffuser separated from the ceiling: $C_h=1,4$

The corrected throw (X_c) is obtained by:

$$X_c = X \cdot C_a / C_h$$

Useful recommendations

1. Maximum distance of diffuser to ceiling.

To obtain an adhering jet with cold air, it is advisable not to exceed the distance of the diffuser with respect to the ceiling (h max.) and the temperature difference Δt (difference between room and supply air temperature) according to the following tables.

For type 50 FR-4:

Δt (° C)	0	6	9	12
h max (m)	0,20	0,10	0,07	0,05

For types 50 FR-1, 50 FR-2, 50 FR-2-L, 50 FR-3:

Δt (° C)	0	6	9	12
h max (m)	0,38	0,21	0,14	0,11

2. Minimum recommended velocity in occupied zone, V_z.

Due to the difference in the temperature of the air in the room with respect to the cold supply air, the following minimum velocities V_z are recommended:

For type 50 FR-4:

Δt (° C)	0	6	9	12
V _z (m/s)	0,15	0,15	0,20	0,25

For types 50 FR-2, 50 FR-2D, 50 FR-2-L:

Δt (° C)	0	6	9	12
V _z (m/s)	0,15	0,18	0,23	0,28

For types 50 FR-1, 50 FR-3:

(diffuser close to exterior / interior wall resp.)

Δt (° C)	0	6	9	12
V _z (m/s)	0,15	0,20	0,25	0,30
	0,15	0,25	0,30	0,35

3. Flow rate measurement

The air flow rate (q_v) is obtained from the product of the effective area of the diffuser (A_k) and its effective velocity (V_k), measured with a hot-wire anemometer (e.g. type TSI- VELOCICALC):

$$q_v(\text{m}^3/\text{h}) = A_k (\text{m}^2) \cdot V_k (\text{m/s}) \cdot 3600$$

The value of A_k is obtained from the quick selection tables. E.g. for a diffuser type 50 FR-4 of size 12x12 the A_k is found to be 0,0435 m^2 .

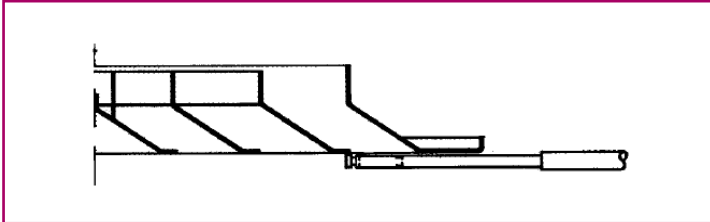

4. Induction effect

It is also possible to obtain the air flow rate induced in the room from the so-called induction factor (q_x/q_o) which is determined by the parameters X_c in m (corrected throw) and the effective discharge area A_k in m^2 , according to the following figures.

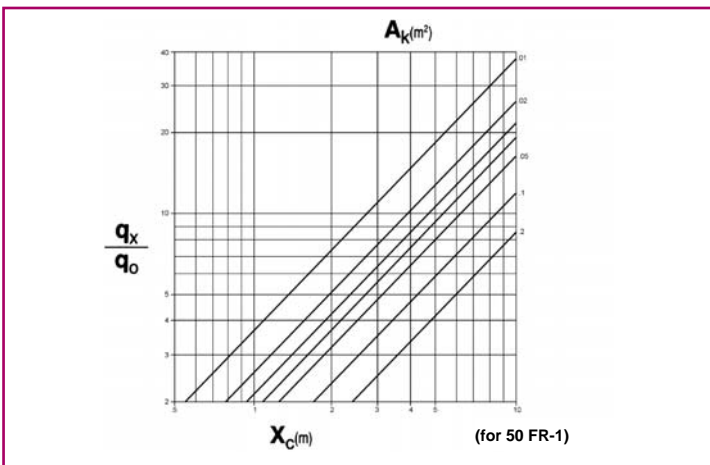
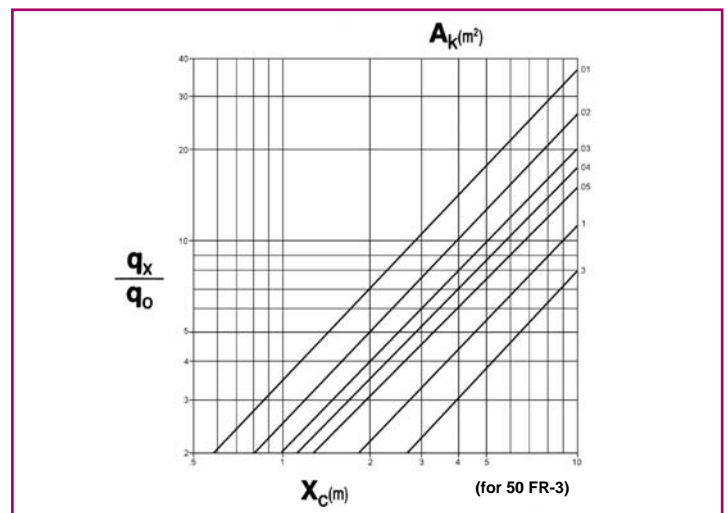
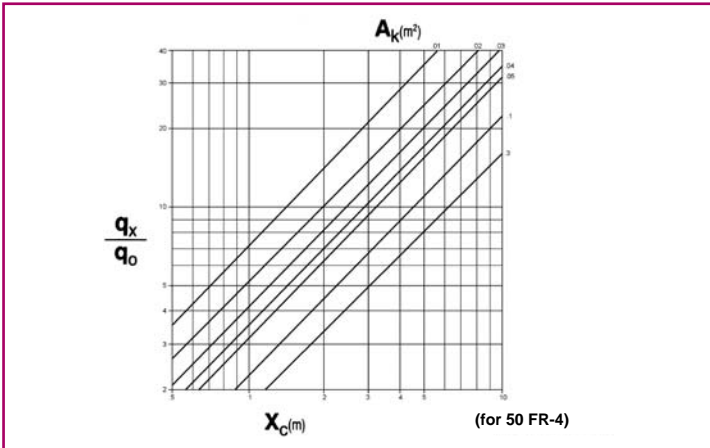
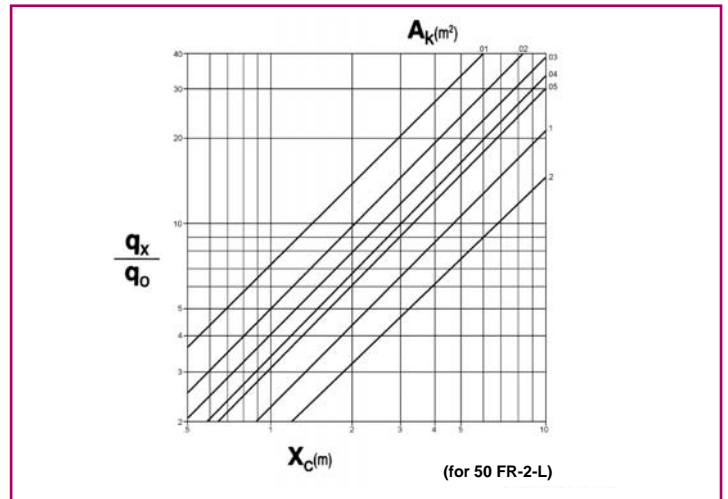
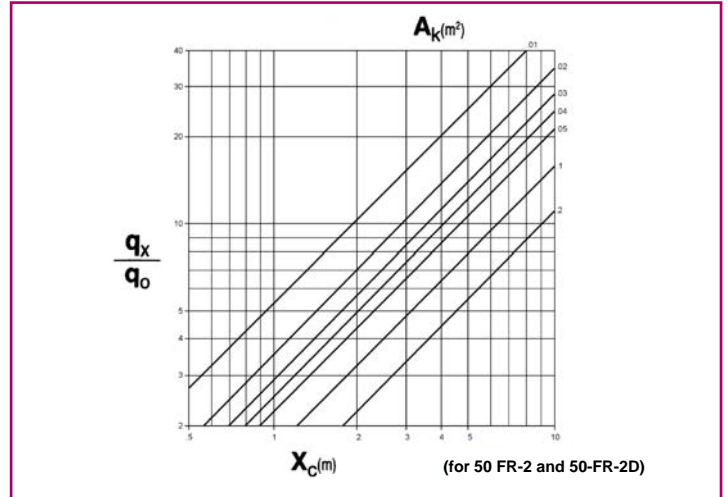

5. Volume control dampers 59 MM and "O".

Technical data

The volume control dampers modify the values of sound level and pressure loss given in the selection tables. Hereafter, and in the corresponding graphs sound levels and total pressure losses (ΔP_t) are presented for the diffuser including the volume control damper, as a function of the parameters V_k (effective velocity) and percentage of opening of the damper.

5.1 Damper 59 MM

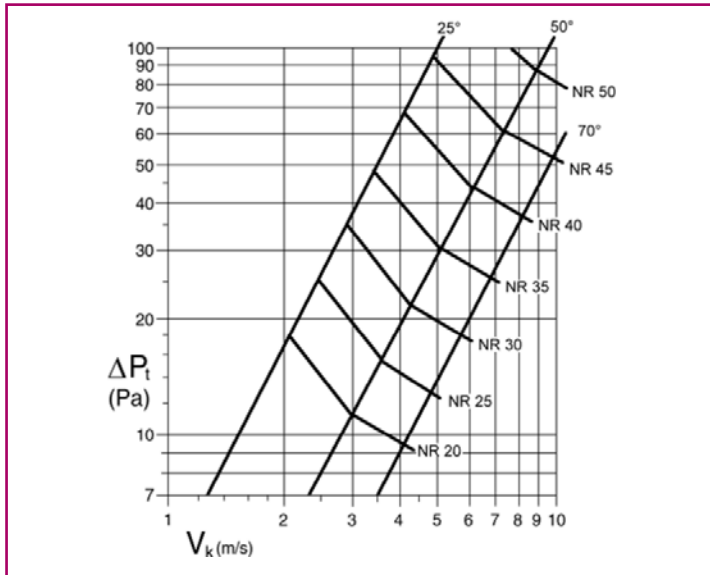

A correction factor should be applied to the sound level as a function of the nominal size of the diffuser according to the following table.

Size	6 x 6	9 x 9	12 x 12
Nominal dim. in mm	150 x 150	225 x 225	300 x 300
NR to be added	-2	1	3

5.2 Damper "O".

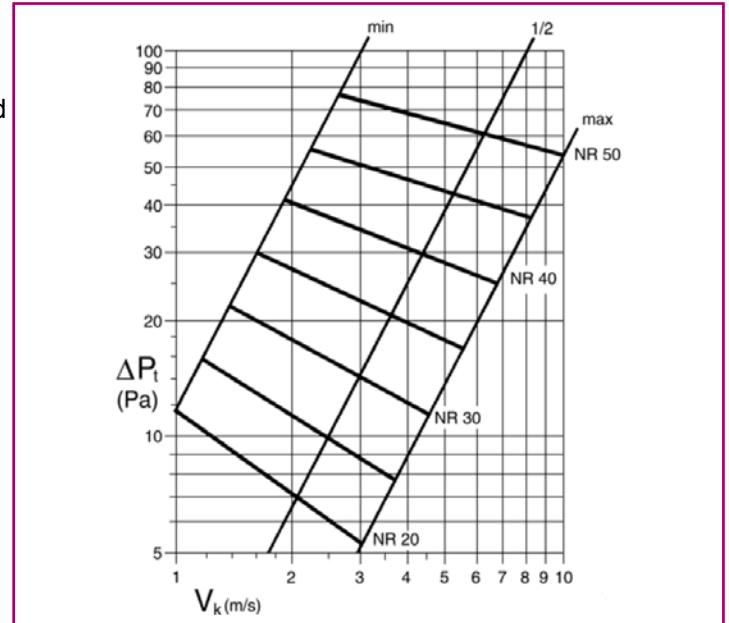

A correction factor should be applied to the sound level as a function of A_k of the diffuser according to the following table.

A_k (m ²)	0,01	0,02	0,03	0,05	0,1	0,2
NR to be added	-5,2	-1,9	0	2,4	5,8	9,1

Other accessories and mounting systems

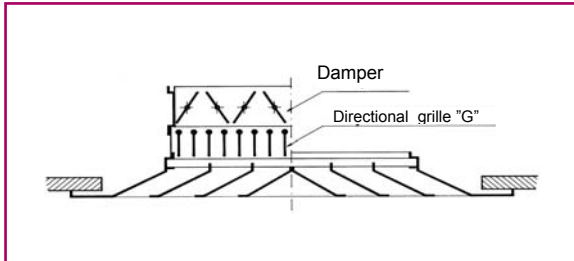

Directional grille "G"

The directional grille G is a flow guide which permits orientation of the air flow, providing more flow in some directions than in others. Positioned at 0° it acts as a flow equaliser in cases where the duct flow is not uniform. Mounting is compatible with damper O and/or mounting system SM, but not with mounting bridges (PM or PMC) or blade damper (59 MM).

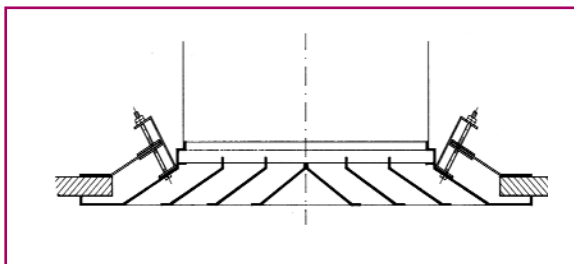

Mounting system "SM"

The mounting system SM consists of clips fixed to the diffuser neck, which provides pressure between the frame of the diffuser and the interior of the false ceiling. They are adjustable in height by means of screws.

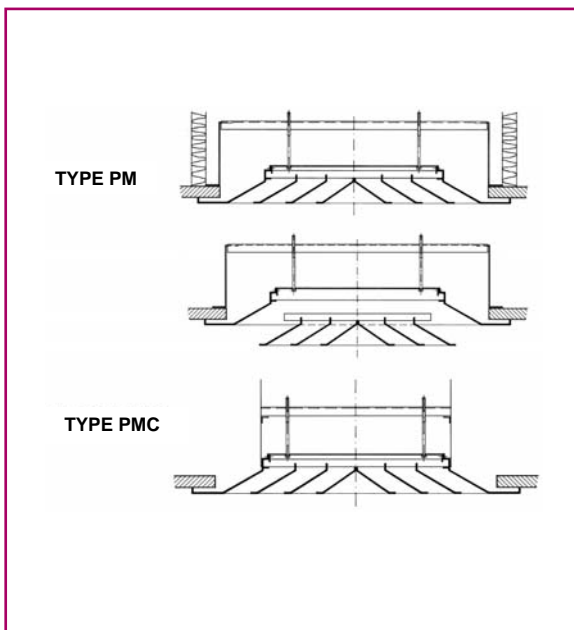

Mounting bridges "PM" and "PMC"

The system with mounting bridge (PM or PMC) is especially indicated for mounting in fibre ducts (PM) or sheet ducts (PMC). When the central core of the diffuser is removed, the mounting bridge can be fixed to the exterior cone of the diffuser by means of screws. The central part can then be placed in its original position.

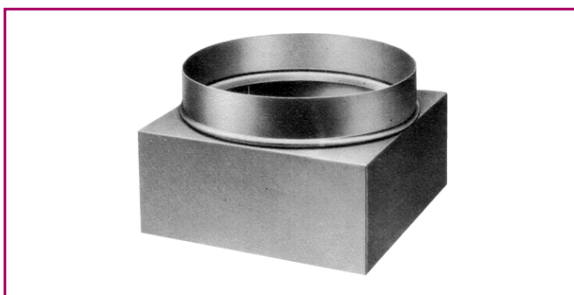

Square-circular transformation piece

Upon request and after consultation, square-circular transformation pieces can be provided for use with circular ducts.

Possible combinations of square diffusers 50 FR-4, 50 FR-1, 50 FR-2, 50 FR-3 with volume control damper and mounting system.

50 FR-4, 50FR-1 50 FR-2, 50FR-3		Damper		Mounting system			Damper + Mounting system					
Size	Dimensions	59 MM	0	PM	PMC	SM	59 MM+ PM	59 MM+ PMC	59 MM+ SM	0 + PM	0 + PMC	0 + SM
6 x 6	150 x 150	•	•	•	•	•	•	•	•			•
9 x 9	225 x 225	•	•	•	•	•	•	•	•			•
12 x 12	300 x 300	•	•	•	•	•	•	•	•			•
15 x 15	375 x 375		•			•						•
18 x 18	450 x 450		•			•						•
21 x 21	525 x 525		•			•						•
24 x 24	600 x 600		•			•						•

Notes

1. Diffuser type 50 FR-3 can be supplied only upto and including size 18x18 (450x450 mm).
2. All square and rectangular diffusers can incorporate the directional grille G as an accessory, compatible with damper O and mounting system SM. The directional grille is not compatible with the mounting bridges (PM and PMC) and the blade damper (59 MM).

Possible combinations of rectangular diffusers 50 FR-2-L with volume control damper and mounting system.

50 FR-2-L		Damper		Mounting system			Damper + Mounting system		
Size	Dimensions	59 MM	0	PM	PMC	SM	0 + PM	0 + PMC	0 + SM
9 x 6	225 x 150		•			•			•
12 x 6	300 x 150		•			•			•
12 x 9	300 x 225		•			•			•
15 x 9	375 x 225		•			•			•
18 x 9	450 x 225		•			•			•

Types and directions of off-standard rectangular diffusers

Other, off-standard, configurations and sizes exist which can be provided upon request and after previous consultation. These rectangular diffuser types only can incorporate damper type O and/or mounting system SM and/or directional grille G.

Being the 1st dimension always the diffuser length and the 2nd the width, the dimensions of the rectangular diffusers which can be supplied are given in the following table.

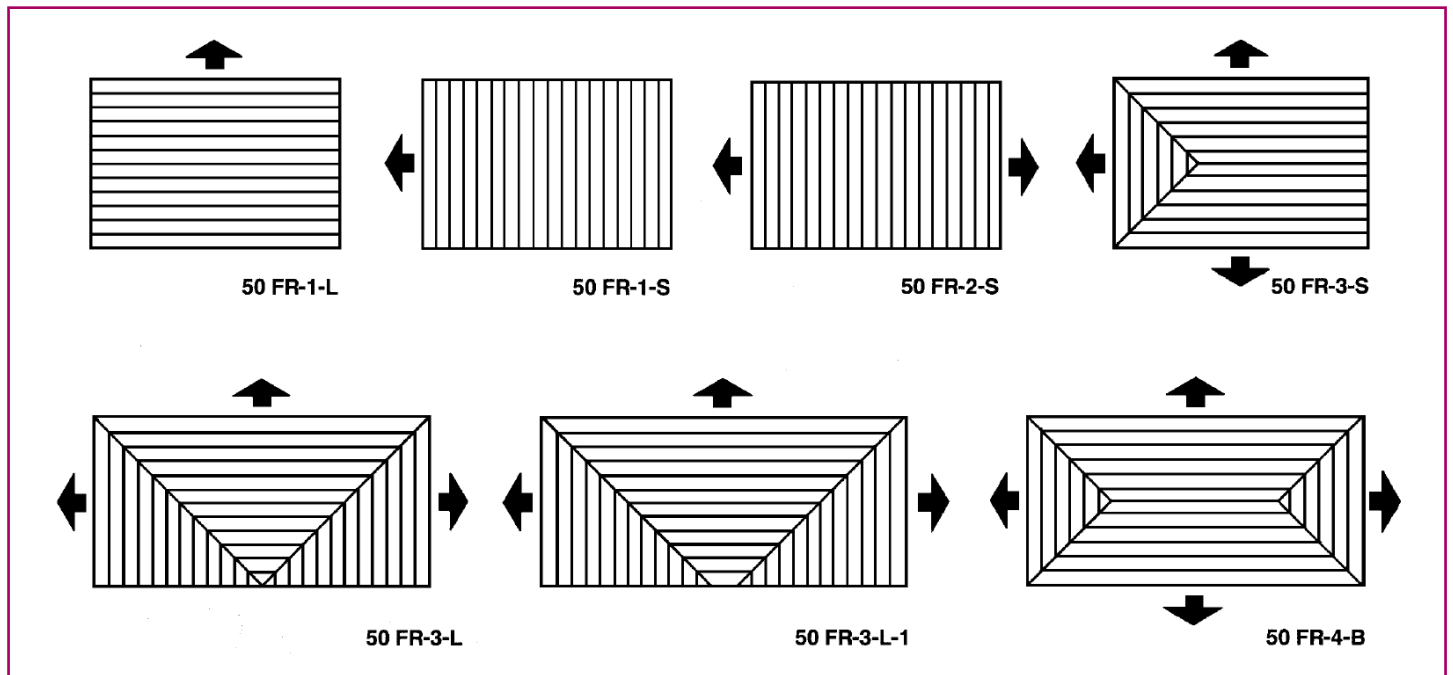

Size	Dimensions	Diffuser type						
		50 FR-1-L	50 FR-1-S	50 FR-2-S	50 FR-3-S	50 FR-3-L	50 FR-3-L-1	50 FR-4-B
9 X 6	225 x 150	•	•	•	•			•
12 X 6	300 x 150	•	•	•	•	•		•
12 X 9	300 x 225	•	•	•	•			•
15 X 6	375 x 150	•	•	•	•		•	•
15 X 9	375 x 225	•	•	•	•			•
15 X 12	375 x 300	•	•	•	•			•
18 X 6	450 x 150	•	•	•	•		•	•
18 X 9	450 x 225	•	•	•	•	•		•
18 X 12	450 x 300	•	•	•	•			•
18 X 15	450 x 375	•	•	•	•			•
21 X 6	525 x 150	•	•	•	•		•	•
21 X 9	525 x 225	•	•	•	•		•	•
21 X 12	525 x 300	•	•	•	•			•
21 X 15	525 x 375	•	•	•	•			•
21 X 18	525 x 450	•	•	•	•			•
24 X 6	600 x 150	•	•	•	•		•	•
24 X 9	600 x 225	•	•	•	•		•	•
24 X 12	600 x 300	•	•	•	•	•		•
24 X 15	600 x 375	•	•	•	•			•
24 X 18	600 x 450	•	•	•	•			•
24 X 21	600 x 525	•	•	•	•			•

Stamped square diffusers

52-FR-4 Stamp

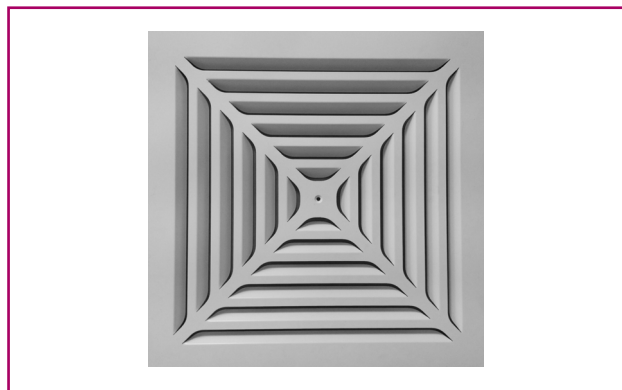

Description

52-FR-4 Stamp model, stamped square diffuser with stationary central core, for air supply in four directions. Suitable for cold and hot air supply. Recommendable installation for ceiling diffuser, equipped with plenum box for lateral discharge or upper discharge. Installation height of 2.5 to 4 m.

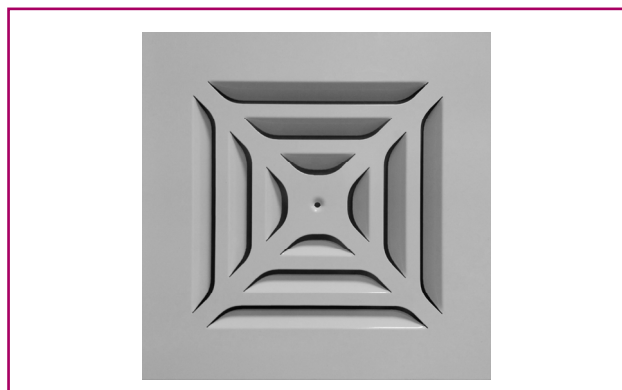

Finishes

Galvanized steel sheet, painted in glossy RAL-9010. Plenum box in galvanized steel sheet, for lateral connection or upper connection. Special finishes by special order.



52-FR Stamp	Series, aluminium diffuser.
4	4 air flow directions.
-	without plenum box
+PS	with unisolated plenum box, upper discharge
+PL	with unisolated plenum box, lateral discharge
+PSI	with isolated plenum box, upper discharge
+PLI	with isolated plenum box, lateral discharge
+PE45	with polystyrene plenum box for diffusers with 595 x 595 mm plaque
Dimensions	Nominal 150 to 600 as per table

Dimensions

Types of plates

NOMINAL	A	B	C	X
150	295	182	56,5	190
225	370	257	56,5	265
300	445	332	56,5	340
375	520	407	56,5	415
450	595	482	56,5	490
500	625	557	34	565
525	670	557	56,5	565
600	745	632	56,5	640

52-FR-4 Stamp-PS

MODEL	A (Ext.)	B	C	Ø D (Ext.)	EXTERNAL DIFFUSER DIMENSION							
150	215	195	190	124	295	370	445	520	595	623	670	745
225	290	270		159								
300	365	345		199								
375	440	420		249								
450	515	495		314								
525	590	570		314								
600	665	645		354								

52-FR-4 Stamp-PL

MODEL	A (Ext.)	B	C	Ø D (Ext.)	EXTERNAL DIFFUSER DIMENSION							
150	215	195	190	124	295	370	445	520	595	623	670	745
225	290	270		159								
300	365	345		199								
375	440	420		249								
450	515	495		314								
525	590	570		314								
600	665	645		354								

Selection table 52-FR-4 Stamp

Q		Nominal A _s [m ²]	150	225	300	375	450	500/525
[m ³ /h]	[l/s]		0,0206	0,0412	0,0435	0,0495	0,0614	0,0815
100	27,8	X [m]	0,6					
		dB(A)	20					
		p _t [Pa]	4					
		V _k [m/s]	1,3					
150	41,7	X [m]	1,0	0,7				
		dB(A)	30	<20				
		p _t [Pa]	10	2				
		V _k [m/s]	2,0	1,0				
200	55,6	X [m]	1,3	0,9	0,9			
		dB(A)	36	26	<20			
		p _t [Pa]	17	4	3			
		V _k [m/s]	2,7	1,3	1,3			
250	69,4	X [m]	1,6	1,2	1,1	1,0		
		dB(A)	42	31	<20	<20		
		p _t [Pa]	27	7	4	1		
		V _k [m/s]	3,4	1,7	1,6	1,4		
300	83,3	X [m]	1,9	1,4	1,3	1,2		
		dB(A)	46	36	21	<20		
		p _t [Pa]	39	10	6	2		
		V _k [m/s]	4,0	2,0	1,9	1,7		
350	97,2	X [m]	2,2	1,6	1,5	1,4	1,3	
		dB(A)	50	39	25	<20	<20	
		p _t [Pa]	54	13	8	3	1	
		V _k [m/s]	4,7	2,4	2,2	2,0	1,6	
400	111,1	X [m]		1,9	1,7	1,6	1,5	1,3
		dB(A)		43	28	22	<20	<20
		p _t [Pa]		17	11	3	2	1
		V _k [m/s]		2,7	2,6	2,2	1,8	1,4
500	138,9	X [m]		2,3	2,2	2,0	1,8	1,6
		dB(A)		48	34	28	23	<20
		p _t [Pa]		27	17	5	3	2
		V _k [m/s]		3,4	3,2	2,8	2,3	1,7
600	166,7	X [m]			2,6	2,5	2,2	1,9
		dB(A)			38	32	28	20
		p _t [Pa]			24	8	4	3
		V _k [m/s]			3,8	3,4	2,7	2,0
700	194,4	X [m]			3,1	2,9	2,6	2,2
		dB(A)			42	36	31	24
		p _t [Pa]			33	10	6	3
		V _k [m/s]			4,5	3,9	3,2	2,4

Q		Nominal A _s [m ²]	300	375	450	500/525	600
[m ³ /h]	[l/s]		0,0435	0,0495	0,0614	0,0815	0,1128
800	222,2	X [m]	3,5	3,3	2,9	2,6	
		dB(A)	45	39	35	27	
		p _t [Pa]	43	13	7	4	
		V _k [m/s]	5,1	4,5	3,6	2,7	
900	250,0	X [m]	3,9	3,7	3,3	2,9	2,4
		dB(A)	48	42	38	30	<20
		p _t [Pa]	55	17	9	6	3
		V _k [m/s]	5,7	5,0	4,1	3,1	2,2
1000	277,8	X [m]	4,4	4,1	3,7	3,2	2,7
		dB(A)	50	45	40	33	<20
		p _t [Pa]	67	21	11	7	4
		V _k [m/s]	6,4	5,6	4,5	3,4	2,5
1250	347,2	X [m]		5,1	4,6	4,0	3,4
		dB(A)		50	46	38	24
		p _t [Pa]		33	18	11	6
		V _k [m/s]		7,0	5,7	4,3	3,1
1500	416,7	X [m]			5,5	4,8	4,1
		dB(A)			50	42	28
		p _t [Pa]			25	16	8
		V _k [m/s]			6,8	5,1	3,7
1750	486,1	X [m]				5,6	4,7
		dB(A)				46	32
		p _t [Pa]				21	11
		V _k [m/s]				6,0	4,3
2000	555,6	X [m]				6,4	5,4
		dB(A)				49	35
		p _t [Pa]				28	15
		V _k [m/s]				6,8	4,9
2250	625,0	X [m]					6,1
		dB(A)					38
		p _t [Pa]					18
		V _k [m/s]					5,5
2500	694,4	X [m]					6,8
		dB(A)					40
		p _t [Pa]					23
		V _k [m/s]					6,2
2750	763,9	X [m]					7,5
		dB(A)					43
		p _t [Pa]					27
		V _k [m/s]					6,8

Symbols

- Q (m³/h): Air flow
- L_{wA} [dB(A)]: Sound power level
- ΔP_t (Pa): Pressure drop
- X (m): Horizontal throw of the air jet for a maximum velocity in the occupied area of 0.25 m/s, for a temperature difference ΔT = -10°C
- V_k (m/s): Effective velocity



52-FR-4 Stamp

THIS CATALOGUE IS INTELLECTUAL PROPERTY

Its reproduction either of a part or its full contents is prohibited without the expressed and authentic consent of KOOLAIR, S.L.

CEN-50.1-1112-02



KOOLAIR, S.L.

Calle Urano, 26

Poligono industrial nº 2 – La Fuensanta

28936 Móstoles - Madrid - (España)

Tel: +34 91 645 00 33

Fax: +34 91 645 69 62

e-mail: info@koolair.com

www.koolair.com